

Sanitary Water Heat Pump

-Operation and Installation Manual -

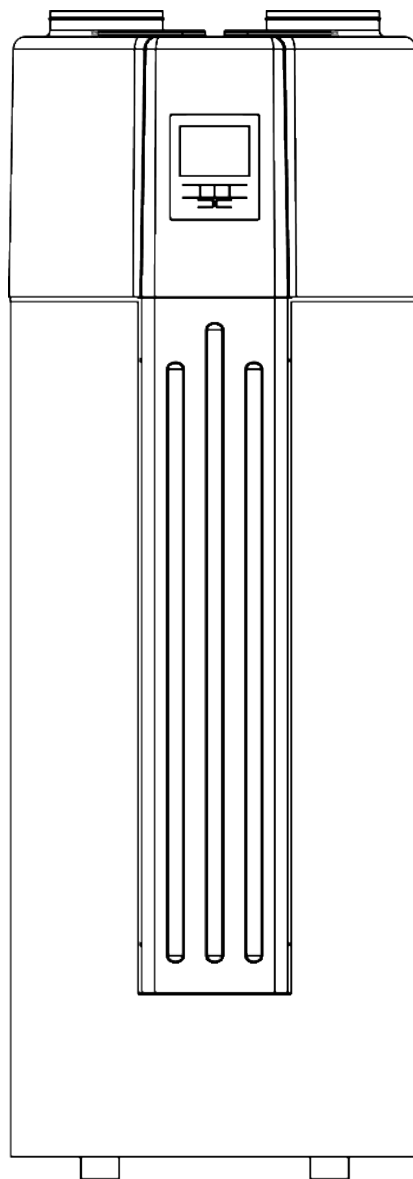

Fjord-1-16/200L; Fjord-1-16/300L



TABLE OF CONTENT

Explanation of symbols display on the unit.....	1
Safety instructions.....	1
Warning.....	1
Cautions.....	3
Special requirements for R290.....	5
INTRODUCTION.....	6
This manual.....	6
The unit.....	6
SAFETY INSTRUCTIONS.....	7
Warning.....	7
Caution.....	8
ITEMS INSIDE PRODUCT BOX.....	9
OVERVIEW OF THE UNIT.....	10
Parts and descriptions.....	10
Dimensions.....	11
How to replace the magnesium stick.....	12
Schematic overview of the water and refrigeration circuit.....	12
INSTALLATION.....	12
Transportation.....	13
Required service space.....	14
Installation overview.....	15
Installation positions.....	16
Water loop connection.....	17
Water affusion and water emptying.....	17
Wire connection.....	17
Trial running.....	18
OPERATION THE UNIT.....	19
User interface and operation.....	19
LED icons.....	21
WIFI.....	23
PARAMETER CHECKING AND ADJUSTMENT.....	31
Parameter list.....	31
Malfunctioning of the unit and error codes.....	32
MAINTENANCE.....	34
TROUBLESHOOTING.....	35
ENVIRONMENTAL INFORMATION.....	35
DISPOSAL REQUIREMENTS.....	35
WIRING DIAGRAM.....	36
TECHNICAL SPECIFICATION.....	38
TEMPERATURE SENSOR R-T CONVERSION TABLE.....	39

Note:

 READ THIS MANUAL CAREFULLY BEFORE STARTING UP THE UNIT. DO NOT THROW IT AWAY.KEEP IT IN YOUR FILES FORFUTUREREERENCE.

 BEFORE OPERATING THE UNIT, MAKE SURE THE INSTALLATION HAS BEEN CARRIED OUT CORRECTLYBY APROFESSIONAL DEALER. IF YOU FEEL UNSURE ABOUT OPERATION, CONTACT YOUR DEALER FOR ADVICE AND INFORMATION.

Explanation of symbols display on the unit.

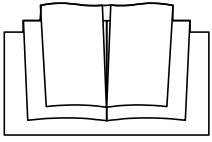
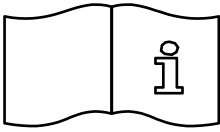
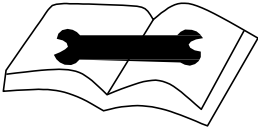
	<p>WARNING</p>	<p>This symbol shows that this appliance used a flammable refrigerant. If the refrigerant is leaked and exposed to an external ignition source, there is a risk of fire.</p>
	<p>CAUTION</p>	<p>This symbol shows that the operation manual should be read carefully.</p>
	<p>CAUTION</p>	<p>This symbol shows that information is available such as the operating manual or installation manual.</p>
	<p>CAUTION</p>	<p>This symbol shows that a service personnel should be handling this equipment with reference to the installation manual.</p>

Safety instructions

In order to prevent personal injury or property damage to users and others, please be sure to follow the following instructions. If ignoring the prompt or wrong operation may cause injury or damage.

The unit shall be installed in compliance with local laws, regulations and standards. Check the voltage and frequency. This machine is only used for grounding socket., must be reliably connected to the ground.

The following security precautions need to be taken into account:

- ✧ Please read the following warnings before installing.
- ✧ Please be sure to check the details that need attention, which includes many contents related to security issues.
- ✧ After reading the installation instructions, be sure to keep them for future reference.

Warning

- This appliance can be used by children aged from 8 years and above and persons with reduced physical, sensory or mental capabilities or lack of experience and knowledge if they have been given supervision or instruction concerning use of the appliance in a safe way and understand the hazards involved. Children shall not play with the appliance. Cleaning and user maintenance shall not be made by children without supervision.
- Tear apart and throw away plastic packaging bags so that children will not play with them. Children playing with plastic bags face danger of death by suffocation.
- Safely dispose of packing materials such as nails and other metal or wood parts that could cause injuries.
- Ensure that the installation of Indoor and outdoor unit is safe and reliable.
- If the machine is not installed firmly or not properly, it will cause damage. The minimum support weight required for installation is 20g/mm², and full consideration should be given to strong winds, hurricanes or earthquakes. When installing the

machine in a closed area or limited space, please consider the size and ventilation of the room to prevent suffocation due to refrigerant leakage.

- That the appliance shall be disconnected from its power source during service and when replacing parts and, if that the removal of the plug is foreseen, it shall be clearly indicated that the removal of the plug has to be such that an operator can check from any of the points to which he has access that the plug remains removed.
- If this is not possible, due to the construction of the appliance or its installation, a disconnection with a locking system in the isolated position shall be provided.
- Improper installation of equipment or accessories may result in electric shock, short-circuit, leakage, fire or other damage to the equipment. Be sure to only use accessories made by the supplier, which are specifically designed for the equipment and make sure to get installation done by a professional.



**Caution: Risk of fire
flammable materials**

- Servicing shall only be performed as recommended by the equipment manufacturer. Maintenance and repair requiring the assistance of other skilled personnel shall be carried out under the supervision of the person competent in the use of flammable refrigerants.
- All the activities described in this manual must be carried out by a licensed technician. Be sure to wear adequate personal protection equipment such as gloves and safety glasses while installation the unit or carrying out maintenance activities.
- The appliance shall be installed in accordance with national wiring regulations.
- Use a specific wire and fix it on the terminal block (so that the connection can avoid the pressure of the wire from being applied to the component).
- Incorrect wiring can cause fire.
- Make certain that all electrical work is carried out by qualified personnel according to the local laws and regulations and this manual using a separate circuit. Insufficient capacity of the power supply circuit or improper electrical construction may lead to electric shocks or fire.
- Be sure to install a ground fault circuit interrupter according to local laws and regulations. Failure to install a ground fault circuit interrupter may cause electric shocks and fire.
- During installation or repair of the unit, please do not unplug or plug in the power supply, and do not leave the unit unattended (It may cause fire or electric shock)
- Do not touch or operate the unit when your hands are wet. (It may cause fire or electric shock)
- Before touching electric terminal parts, turn off power switch.
- When service panels are removed, live parts can be easily touched by accident.
- Do not touch water pipes during and immediately after operation as the pipes may be hot and could burn your hands. To avoid injury, give the piping time to return to normal temperature or be sure to wear protective gloves.
- Before touching electrical parts, turn off all applicable power to the unit.
- After completing the installation work, check to make sure that there is no refrigerant leakage.
- Never directly touch any leaking refrigerant and the refrigerant pipes.
- It could cause severe frostbite. During and immediately after operation as the refrigerant pipes may be hot or cold, depending on the condition of the refrigerant flowing through the refrigerant piping, compressor and other refrigerant cycle parts.

Burns or frostbite are possible if you touch the refrigerant pipes. To avoid injury, give the pipes time to return to normal temperature or, if you must touch them, be sure to wear protective gloves.

- **Do not touch the internal parts (pump, backup heater, etc.) during and immediately after operation.**
- Touching the internal parts can cause burns. To avoid injury, give the internal parts time to return to normal temperature or, if you must touch them, be sure to wear protective gloves.
- **Do not pierce or burn.**
- **Do not place heaters or other electrical appliances near the power cord** (It may cause fire or electric shock)
- **Please note that water cannot be poured directly from the unit. Do not let water enter electrical components.** (It may cause fire or electric shock)

 **If the unit is not used for a long time, it is recommended not to turn off the power supply. If the power is turned off, the protection devices of some products (such as water pump anti lock and anti freezing device) will not be available.**

Cautions

- **Please carry out drainage system and the pipeline work according to the instructions.**
- If the drainage system or pipeline is defective, water leakage may occur, and it should be dealt with immediately to avoid getting other household products wet and damaged.
- **Install the power wire at least 3 feet (1 meter) away from televisions or radios to prevent interference or noise. (Depending on the radio waves, a distance of 3 feet (1 meter) may not be sufficient to eliminate the noise.)**
- **Please do not clean the unit when the power is on. When cleaning the unit, please turn off the power after shutting down. Otherwise, you may be injured by a high-speed fan or electric shock.**
- **Do not use means to accelerate the defrosting process or to clean, other than those recommended by the manufacturer.**
- **Do not wash the unit. This may cause electric shocks or fire.**
- **Do not install the unit in the following places:**

- Where there is mist of mineral oil, oil spray or vapors. Plastic parts may deteriorate, and cause them to come loose or water to leak.

- Where corrosive gases (such as sulfurous acid gas) are produced. Where corrosion of copper pipes or soldered parts may cause refrigerant to leak.

- Where there is machinery which emits electromagnetic waves. Electromagnetic waves can disturb the control system and cause equipment malfunction.

- Where flammable gases may leak, where carbon fiber or ignitable dust is suspended in the air or where volatile flammables such as paint thinner or gasoline are handled. These types of gases might cause a fire.

- Where the air contains high levels of salt such as near the ocean.

- Where voltage fluctuates a lot, such as in factories.

- In vehicles or vessels.

- Where acidic or alkaline vapors are present.

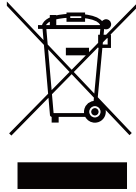

- This marking indicates that this product should not be disposed with other household wastes throughout the EU. To prevent possible harm to the environment or human health from uncontrolled waste disposal, recycle it responsibly to promote the sustainable reuse of material resources. To return your used device, please use the return and collection systems or contact the retailer where the product was purchased. They can take this product for environmental safe recycling.

- **DISPOSAL: Do not dispose this product as unsorted municipal waste.**

Collection of such waste separately for special treatment is necessary. Do not dispose of electrical appliances as municipal waste, use separate collection facilities. Contact your local government for information regarding the collection systems available. If electrical appliances are disposed of in landfills or dumps, hazardous substance can leak into the groundwater and get into the food chain, damaging your health and well-being.

- **Confirm the safety of the installation area (walls, floors, etc.) without hidden dangers such as water, electricity, and gas before wiring/pipes.**
- **Before installation , check whether the user's power supply meets the electrical installation requirements of unit (including reliable grounding , leakage , and wire diameter electrical load, etc.). If the electrical installation requirements of the product are not met, the installation of the product is prohibited until the product is rectified.**
- **Product installation should be fixed firmly, Take reinforcement measures, when necessary.**
- **When the unit has problems or peculiar smell, please do not continue to operate the unit.**
- Turn off the power immediately and stop the machine. Otherwise, electric shock or fire may be caused.
- **Please be careful when the product is not packaged or installed.**
- Harp edges can cut people. Take special care of the edges and fins of the heat exchanger.
- **After installation or maintenance, please check whether the refrigerant or refrigerant will leak.**
- If the refrigerant is insufficient, the unit will not work normally.
- **He installation of external and internal machines must be flat and firm.**
- Avoid vibration and water leakage.
- **Do not put your fingers into the fan and evaporator.**
- High speed fans can cause serious injury.
- **In order to avoid the danger of inadvertently resetting the thermal breaker, the equipment cannot use external switching devices, such as timers, or be connected to a circuit that is often open or closed.**
- **This device is not designed for people with weak physical or mental behavior ability (including children), as well as people who have no use experience and do not understand the heating system. Unless it is used under the safety guidance and supervision of the person in charge, or has received training on the use of this equipment. Children should use the equipment under the supervision of adults to ensure their safe use of the equipment.**

- If the power cord is damaged, it must be replaced by the manufacturer or its service agent or the same professional person to avoid danger. The cut-off device shall be incorporated into the fixed wiring, and the contact spacing gap of each effective conductor shall be at least 3mm.



Special requirements for R290

- Do NOT have refrigerant leakage and open flame.
- Be aware that the R290 refrigerant does NOT contain an odour.
- The appliance shall be stored so as to prevent mechanical damage and in a well-ventilated room without continuously operating ignition sources (example: open flames, an operating gas appliance) and the room size corresponds to the room area as specified for operation.
- Do NOT re-use joints which have been used already.
- Joints made in installation between parts of refrigerant system shall be accessible for maintenance purposes.
- Make sure installation, servicing, maintenance and repair comply with instructions and with applicable legislation (for example national gas regulation) and are executed only by authorized persons.
- Pipework should be protected from physical damage.
- Installation of pipework shall be kept to a minimum.



About hydrocarbon refrigerant

- This air-conditioning unit contains hydrocarbon refrigerant. For specific information on the type of gas and the amount, please refer to the relevant label on the unit itself. Compliance with national gas regulations shall be observed.

- Installation, service, maintenance and repair of this unit must be performed by a certified technician.

- Product installation and recycling must be performed by a certified technician.

- If the system has a leak-detection system installed, it must be checked for leaks at least every 12 months. When the unit is checked for leaks, proper record-keeping of all checks is strongly recommended.



Frequency of Refrigerant Leakage Checks

- For unit that contains fluoridated greenhouse gases in quantities of 5 tonnes of CO₂ equivalent or more, but of less than 50 tonnes of CO₂ equivalent, at least every 12 months, or where a leakage detection system is installed, at least every 24 months.
- For unit that contains fluoridated greenhouse gases in quantities of 50 tonnes of CO₂ equivalent or more, but of less than 500 tonnes of CO₂ equivalent at least every six months, or where a leakage detection system is installed, at least every 12 months.
- For unit that contains fluoridated greenhouse gases in quantities of 500 tonnes of CO₂ equivalent or more, at least every three months, or where a leakage detection system is installed, at least every six months.
- This air-conditioning unit is a hermetically sealed equipment that contains fluoridated greenhouse gases.

INTRODUCTION

This manual

This manual includes the necessary information about the unit. Please read this manual carefully before you use and maintain the unit.

The unit

The hot water heat pump is one of the most economical systems to heat the water for family domestic use. Using free renewable energy from the air, the unit is highly efficient with low running costs. Its efficiency can be up to 3 ~ 5 times more than conventional gas boilers or electrical heaters.

Waste Heat recovery

Units can be installed near the kitchen, in the boiler-room or the garage, basically in every room which has a large number of waste-heat so that the unit has the higher energy efficiency even with very low outside temperatures during the winter.

Hot water and dehumidification

Units can be placed in the laundry room or clothing room. When it produces hot water it lowers the temperature and dehumidifies the room as well. The advantages can be experienced particularly in the humid season.

Storage room cooling

Units can be placed in the storage room as the low temperature keeps the food fresh.

Hot water and fresh air ventilation

Units can be placed in the garage, gym, basement etc. When it produces hot water, it cools the room and supplies fresh air.

Compatible with different energy sources

Units can be compatible with solar panels, external heat pumps, boilers or other different energy sources.

Ecological and Economical Heating

Units are the most efficient and economical alternative to both fossil fuel boilers and heating systems. By making use of the renewable source in the air, it consumes much less energy.

Compact design

Units are especially designed for offering sanitary hot water for family use. Its extremely compact structure and elegant design are suitable for indoor installation.

Multiple Functions

The special design of the air inlet and outlet makes the unit suitable for various ways of connections. With different ways of installation, the unit can work as just a heat pump but also as a fresh air blower, a dehumidifier, or an energy recovery device.

Other features

Stainless steel tank and a magnesium stick assure the durability of components and the tank.

Highly efficient compressor with the R290 refrigerant.

Electrical element available in the unit as a back-up, assuring constant hot water even in extreme cold winters.

SAFETY INSTRUCTIONS

To prevent injury to the user, other people, or property damage, the following instructions must be followed. Incorrect operation due to ignoring of instructions may cause harm or damage.

Install the unit only when it complies with local regulations, by-laws and standards. Check the main voltage and frequency. This unit is only suitable for earthed sockets, connection voltage 220 – 240 V ~ / 50Hz.

The following safety precautions should always be taken into account:

- Be sure to read the following WARNING before installing the unit.
- Be sure to observe the cautions specified here as they include important items related to safety.
- After reading these instructions, be sure to keep it in a handy place for future reference.

Warning



Do not install the unit yourself.

Incorrect installation could cause injury due to fire, electric shock, the unit falling or leakage of water. Consult the dealer from whom you purchased the unit or a specialized installer.

Install the unit securely in a place.

When insufficiently installed, the unit could fall causing injury. The bearing surface should be flat to bear the weight of the unit and suitable for installing the unit without increasing noise or vibration. When installing the unit in a small room, please take measures (like sufficient ventilation) to prevent the asphyxia caused by the leakage of refrigerant.

Use the specified electrical wires and attach the wires firmly to the terminal board (connection in such a way that the stress of the wires is not applied to the sections).

Incorrect connection and fixing could cause a fire.

Be sure to use the provided or specified parts for the installation work.

The use of defective parts could cause an injury due to possible fire, electric shocks, the unit falling etc.

Perform the installation securely and please refer to the installation instructions.

Incorrect installation could cause an injury due to possible fire, electric shocks, the unit falling, leakage of water etc.

Perform electrical work according to the installation manual and be sure to use a dedicated section, fused with 16A.

If the capacity of the power circuit is insufficient or there is an incomplete electrical circuit, it could result in a fire or an electric shock.

The unit must always have an earthed connection.

If the power supply is not earthed, you may not connect the unit.

Never use an extension cable to connect the unit to the electric power supply.

If there is no suitable, earthed wall socket available, have one installed by a recognized electrician.

Do not move/repair the unit yourself.

If the supply cord is damaged, it must be replaced by the manufacturer or its service agent or a similarly qualified person in order to avoid a hazard. Improper movement or repair on the unit could lead to water leakage, electrical shock, injury or fire.

The unit is no intended for use by children.

This appliance can be used by children aged from 8 years and above and persons with reduced physical, sensory or mental capabilities or lack of experience and knowledge if they have been given supervision or instruction concerning use of the appliance in a safe way and understand the hazards involved. Children shall not play with the appliance. Cleaning and user maintenance shall not be made by children without supervision.

Do not tear off the labels on the unit.

The labels are for the purpose of warning or reminding, keeping them can ensure your safe operations.

Caution



Do not install the unit in a place where there is a chance of flammable gas leaks.

If there is a gas leak and gas accumulates in the area surrounding the unit, it could cause an explosion.

Perform the drainage/piping work according to the installation instruction.

If there is a defect in the drainage/piping work, water could leak from the unit and household goods could get wet and be damaged.

Do not clean the unit when the power is 'ON'.

Always shut 'OFF' the power when cleaning or servicing the unit. If not, it could cause an injury due to the high speed running fan or an electrical shock.

Do not continue to run the unit when there is something wrong or there is a strange smell.

The power supply needs to be shut 'OFF' to stop the unit; otherwise this may cause an electrical shock or fire.

Do not put your fingers or others into the fan, or evaporator.

The inside parts of the heat pump may run at high speed or high temperature, they could cause serious injury. Do not remove the grills on the fan outlet and top cover.

The hot water probable need to mix with cold water for terminal usage, too hot water (over 50°C) in the heating unit may cause injury.

The installation height of power supply should be over 1.8m, if any water may spatter, the unit can be safe from water.

ITEMS INSIDE PRODUCT BOX

Before starting the installation, please make sure that all parts are found inside the box.

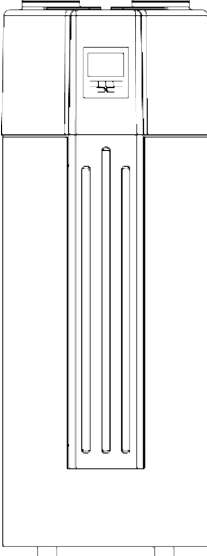
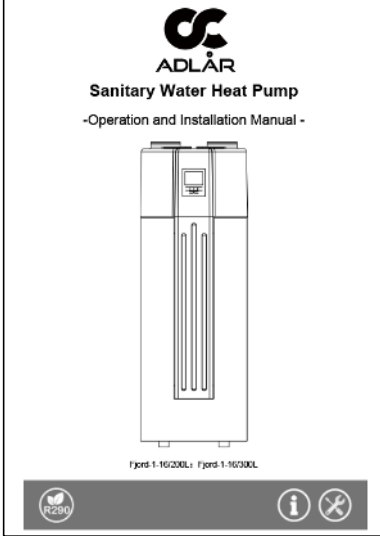
The Unit Box		
Item	Image	Quantity
Domestic hot water heat pump		1
Operation and Installation Manual		1

OVERVIEW OF THE UNIT

Parts and descriptions

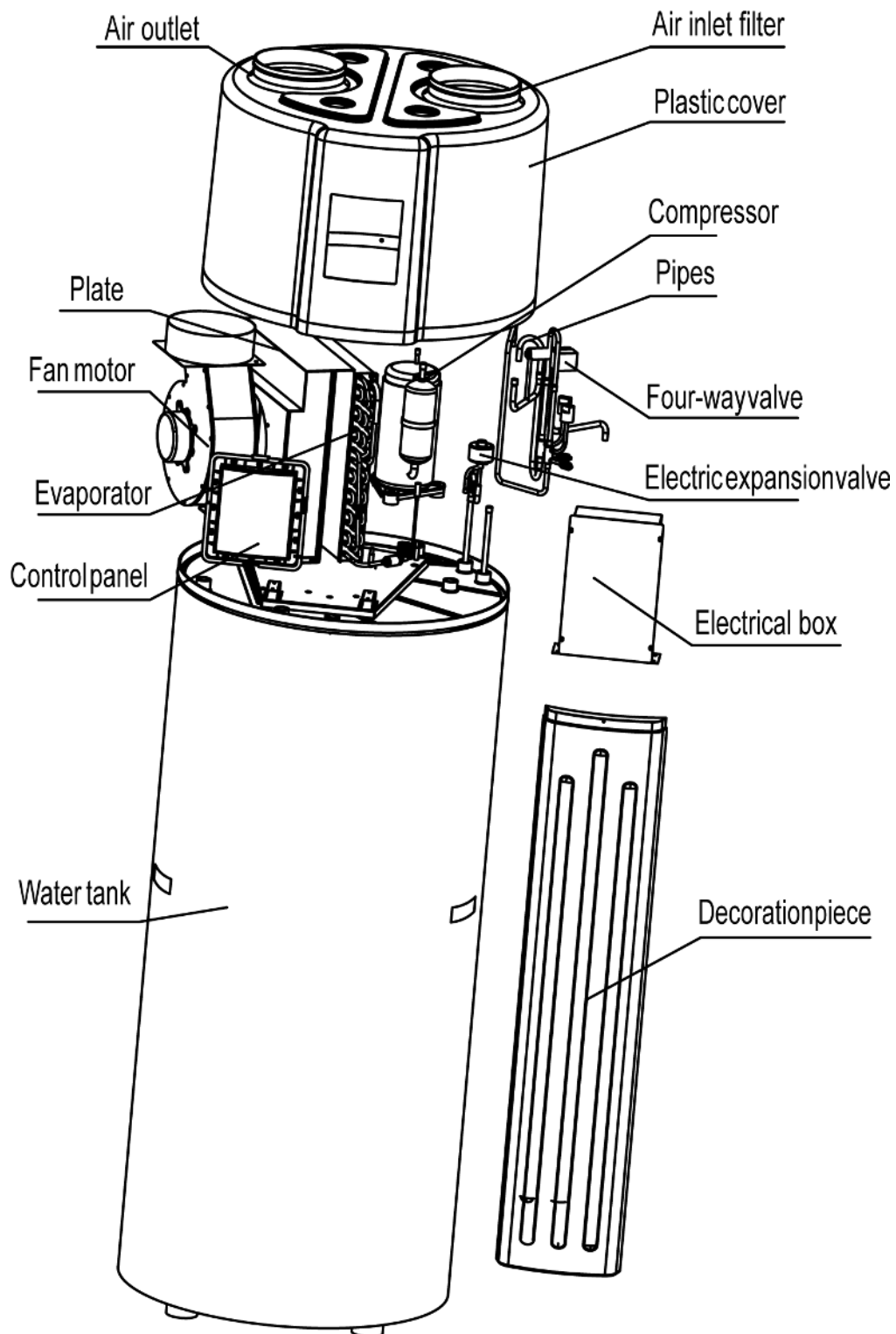

Dimensions

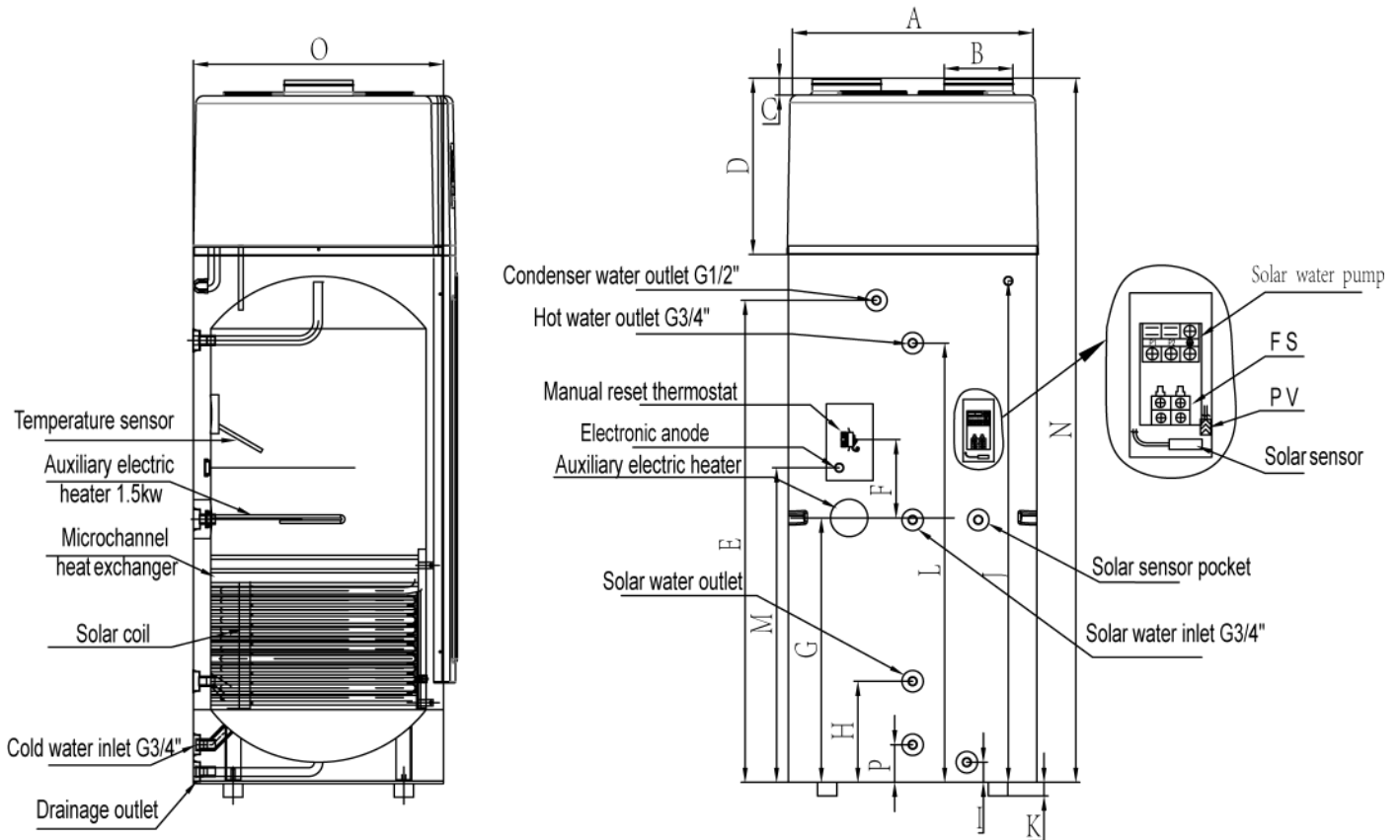

	200L	300L
A	Φ565	Φ650
B	Φ177	Φ177
C	40	40
D	455	455
E	1135	1265
F	238	255
G	600	665
H	250	250
I	41	41
J	1185	1315
K	35	35
L	1020	1155
M	764	905
N	1750	1850
O	Φ560	Φ640

Remark: (With magnesium stick)

- 1) The extra heat source is optional.
- 2) Add the solar control. While the parameter 14= 1, solar energy control is available. The terminal “TO PUMP” is connected solar energy water pump, “FS” is connected the flow switch of solar water circuit, “SOLAR SENSOR” is testing the temp of solar thermal collector.
- 3) The Magnesium stick is an anti-corrosion element. It is assembled in the water tank to avoid the creation of fur around the inside tank and to protect the tank, and other components. It can help to extend the life-span of the tank. **Check the magnesium stick every half year and change it if it has been used out!**

How to replace the magnesium stick

- Turn the power of the unit 'OFF' and pull out the plug.
- Drain all the water out of the tank.
- Remove the old magnesium stick from the tank.
- Replace the new magnesium stick.
- Recharge the water.

Remark: (With electrical anod anti-corrosion system)

- 1) The electrical anod anti-corrosion system is optional.
- 2) Electrical anod anti-corrosion system is maintenance free system and mainly consists of controller and titanium electrode, which makes sure the inner wall of the stainless steel tank is always protected against corrosion efficiently.

When the controller reports the related fault of the electronic anode, please contact the local service provider for on-site repair in time. In addition, the system will prohibit auxiliary electrical heater work under the fault state, and the heat pump is only allowed to work for 3 days, after that the whole unit will be locked and cannot continue to work.

Schematic overview of the water and refrigeration circuit

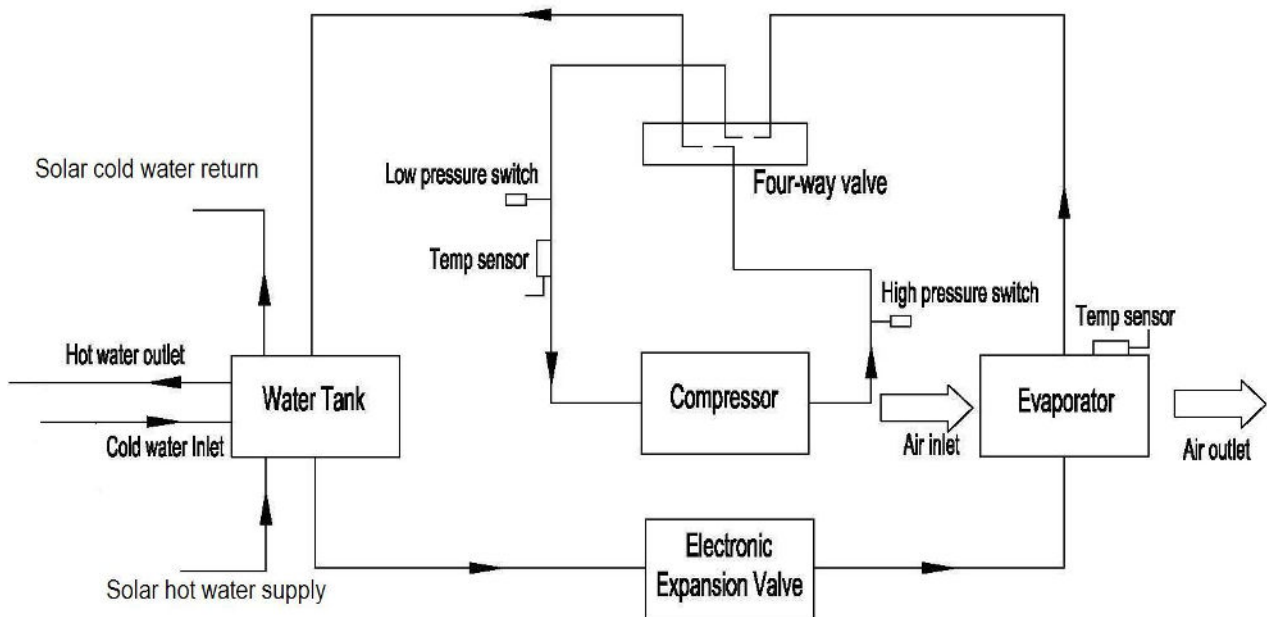

Note: Solar heat exchange coil is optional.

Choose the suitable unit

Please refer to the table below to choose the suitable unit.

Family members	Tank capacity
2 ~ 3 people	200L
More than 6 people	300L

Note: The table is just for reference.

INSTALLATION

WARNING

- Asked your supplier to install the unit. Incomplete installation performed by yourself may result in a water leakage, electric shock, or fire.
- Indoor installation is highly recommended. It is not allow to install the unit at outdoor or rain achieving place.

- The installation place without direct sunlight and other heat supplies is recommended. If no way to avoid these, please install a covering.
- The unit must be securely fixed to avoid noise and shaking.
- Make sure that there's no remora around the unit.
- In the place where there is strong wind, fix the unit in the location protected from the wind.

Transportation

As a rule, the unit is to be stored and/or transported in its shipping container in upright position and without water charge. For a transport over short distance (provided that it is done with care), an inclination angle up to 45 degrees is permitted, both during transport and storage. Ambient temperatures of -20 to $+70$ degrees Celsius are permitted.

- Transport using a forklift

When transported by a forklift, the unit must remain mounted on the pallet. The lifting rate should be kept to a minimum. Due to its top-heaviness, the unit must be secured against tipping over. To prevent any damage, the unit must be placed on a level surface.

- Manual transport

For the manual transport, a wooden/plastic pallet can be used. Using ropes or carrying straps, a second or third handling configuration is possible. With this type of handling, it is advised that the maximum permissible inclination angle of 45 degree is not exceeded. If transport in an inclined position cannot be avoided, the unit should be taken into operation one hour after it has been moved into final position.

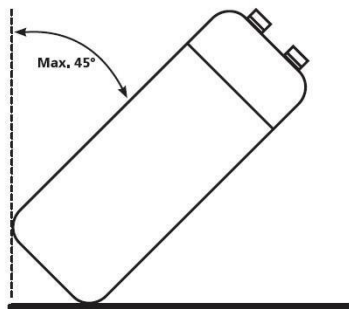

ATTENTION: DUE TO THE HIGH CENTER OF GRAVITY, LOW OVERTURNING MOMENT, THE UNIT MUST BE SECURED AGAINST TIPPING OVER.

Required service space

Below you will find the minimum space required to be able to complete service and maintenance tasks on the units.

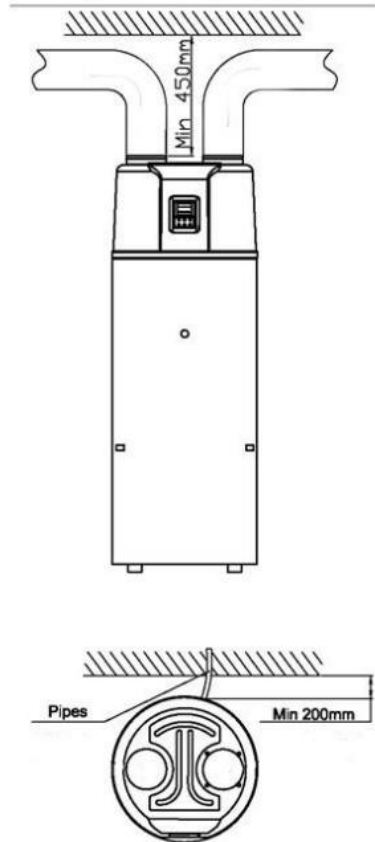

Note:

- If air inlet and/or outlet pipes are connected, portion airflow and capacity in heat pump unit will lose.
- If the unit connects with air ducts it should be DN 180mm for pipes or 180mm internal diameter flexible hose. Total length of the ducts should not be longer than 8m or the maximum static pressure should not exceed than 60Pa. Be in mind of bending site of the duct no more than 4m.

Installation overview

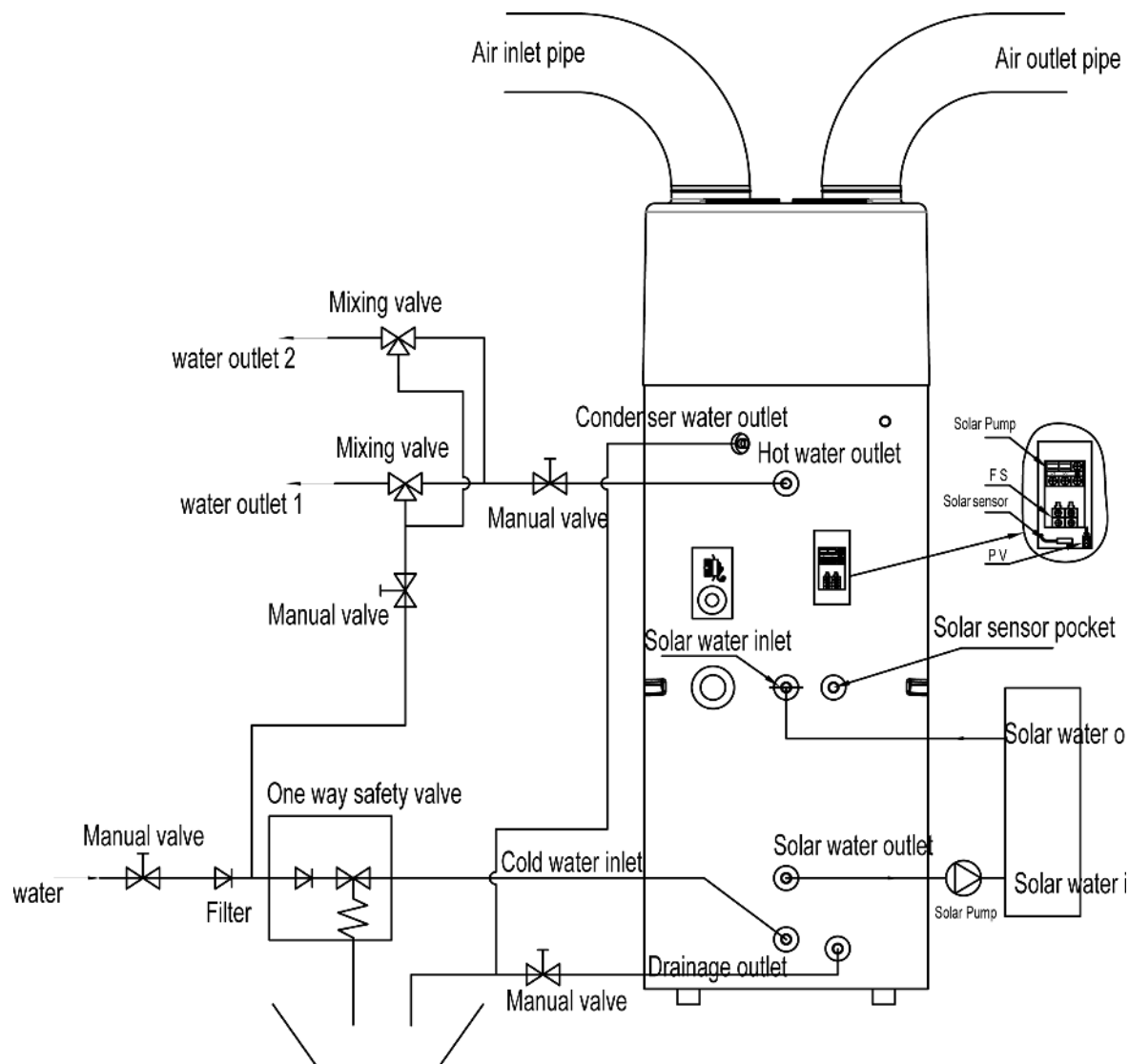

Note: Solar heat exchange coil is optional.

ATTENTION:

- The one-way safety valve must be installed. If not, it could cause damage to the unit, or even hurt people. The set point of this safety valve is 0.7 MPa. For the installation place please refer to the pipeline connection sketch.
- The discharge pipe connected to the one-way safety valve is to be installed in a continuously downward direction and in a frost-free environment.
- The water may drip from the discharge pipe of the one-way safety valve and that this pipe must be left open to the atmosphere.
- The one-way safety valve is to be operated regularly to remove lime deposits and to verify that it is not blocked. Please beware of burn, because of the high temperature of water.
- The tank water can be drained through the drainage hole on the bottom of the tank.
- After all the pipes installed turn on the cold water inlet and hot water outlet to fill the tank. When there is water normally following out from water outlet, the tank is full. Turn off all valves and check all pipes. If any leakage, please repair.

- If the inlet water pressure is less than 0.15MPa, a pressure pump should be installed at the water inlet. For ensure the long safety using age of tank at the condition of water supply hydraulic higher than 0.65MPa, a reducing valve should be mounted at the water inlet pipe.
- Filters are needed in the air inlet. If the unit is connected with ducts, filter in there must be put forward to the air inlet of duct.
- To fluently drain condensate water from evaporator, please install the unit at the horizontal floor. Otherwise, please make sure the drain vent is at the lowest place. Recommending the inclination angle of unit to be ground should no more than 2 degree.

Installation positions

- (1) Waste heat can be useful heat
Units can be installed near the kitchen, in the boiler-room or the garage, basically in every room which has a large number of waste-heat so that the unit has the higher energy efficiency even with very low outside temperatures during the winter.



- (2) Hot water and dehumidification
Units can be placed in the laundry room or clothing room. When it produces hot water it lowers the temperature and dehumidifies the room as well. The advantages can be experienced particularly in the humid season.



- (3) Solar panel or external heat pump could be the second heat source
Units can work with solar panel, external heat pump, boiler or other different energy source.

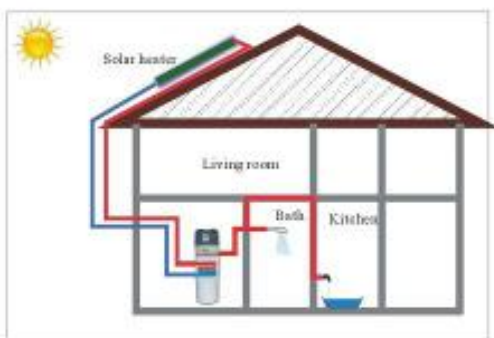

NOTE:

- Choose the right path to move the unit.
- This unit complies with the relevant technical standards of electrical equipment.

Water loop connection

Please pay attention to the below points when connecting the water loop pipe:

1. Try to reduce the water loop resistance
2. Make sure there is nothing in the pipe and the water loop is smooth, check the pipe carefully to see if there is any leak, and then pack the pipe with the insulation.
3. Install the one way valve and safety valve in the water circulation system.
4. The nominal pipe wide of the field- installed sanitary installations must be selected on the basis of the available water pressure and the expected pressure drop within the piping system.
5. The water pipes may be of the flexible type. To prevent corrosion damage, make sure that the materials used in the piping system are compatible.
6. When installing the pipe-work on the customers' site, any contamination of the piping system must be avoided.
- 7.

Water affusion and water emptying

Water Affusion:

If the unit is used for the first time or used again after emptying the tank, please make sure that the tank is full of water before turning on the power.

- Open the cold water inlet and hot water outlet.
- Start the water affusion. When there is water normally flowing out from the hot water outlet, the tank is full.
- Turn off the hot water outlet valve and water affusion is finished.



ATTENTION: Operation without water in water tank may result in damage of auxiliary e-heater!

Water emptying:

If the unit needs cleaning, moving etc, the tank should be emptied.

- Close the cold water inlet
- Open the hot water outlet and open the manual valve of drainpipe
- Start the water emptying.
- After emptying, close the manual valve.
-

Wire connection

- The specification of the power supply wire is 3*2.5 mm².
- There must be a switch when connecting the unit to the power system. The current of the switch is 16A.
- The unit must be installed a Creepage Breaker near the power supply and must be effectively earthed. The specification of the creepage breaker is 30mA, less than 0.1sec.

THE APPLIANCE SHALL BE INSTALLED IN ACCORDANCE WITH NATIONAL WIRING REGULATIONS.

Trial running

Checks before trial running

- Check both the water in the tank as well as the water pipe connection.
- Check the power system, make sure that the power supply is normal and the wire connection is ok.
- Check the inlet water pressure, make sure that the pressure is sufficient (above 0.15Mpa).
- Check if any water flows out from the hot water outlet, make sure that the tank is full of water before turning on the power.
- Check the unit; make sure everything is ok before turning 'ON' the power of the unit, check the light on the wire controller when the unit runs.
- Use the wire controller to start the unit.
- Listen to the unit carefully when turning 'ON' the power of the unit. Turn the power 'OFF' when you hear an abnormal sound.
- Measure the water temperature, to check the undulation of the water temperature.
- Once the parameters have been set, the user cannot change the parameters optionally. Please use a qualified service person to do this.

PARAMETER CHECKING AND ADJUSTMENT

Parameter list

Some parameters can be checked and adjusted by the controller. Below is the parameter list.

Parameter No.	Description	Range	Default	Remarks
0	Tank water setting temp.	10 ~ 70°C	50°C	Adjustable
1	Water temperature gap to restart	2 ~ 15°C	5°C	Adjustable
2	E-heater off tank water temp	10 ~ 85°C	55°C	Adjustable
3	E-heater delay time	0 ~ 90min	6	t * 5 min
4	Week disinfection temperature	50 ~ 70°C	70°C	Adjustable
5	High temp disinfection time	0 ~ 90 min	30 min	Adjustable
6	Defrosting period	30~90 min	45 min	Adjustable
7	Defrosting entry coil temp.	-30 ~ 0°C	-7°C	Adjustable
8	Defrosting exit coil temp.	2 ~ 30°C	13°C	Adjustable
9	Max defrosting cycle period	1 ~ 12 min	8 min	Adjustable
10	Electronic expansion valve adjustment	0/1	1	Adjustable (0-manual, 1-auto)
11	Target over-heat degree	-9 ~ 9°C	5°C	Adjustable
12	Steps of manually adjusting the electronic expansion valve	10 ~ 50 step	35 step	Adjustable
13	Disinfection start up time adjusting	0~23	23	Adjustable(hour)
14	Parameter of solar water pump	0/1	1	Adjustable(0 without water pump, 1with water pump)
15	Solar water pump star return difference	2-20°C	10	Adjustable
16	High temp disinfection frequency	7-28day	7	Adjustable
17	Temperature setting mode	0/1	1	Adjustable (0-manual, 1-auto)
18	Set temp with PV	10-70°C	60	Adjustable
19	Set temp without PV	10-70°C	50	Adjustable
20	When electric anode is defective, heat pump working time	0-7 days	3	Adjustable
21	Upper limit of electric anode voltage	3.5-4.5V	4.0V	Adjustable Actual=set value x 10
22	Lower limit of electric anode voltage	1.0-2.0V	1.5V	Adjustable Actual=set value x 10
A	Lower tank water temp.	-9 ~ 99°C	Actual testing value. Error code P1 will	

			be shown in case of a malfunction
B	Upper tank water temp.	-9 ~ 99°C	Actual testing value. Error code P2 will be shown in case of a malfunction
C	Evaporator coil temp.	-9 ~ 99°C	Actual testing value. Error code P3 will be shown in case of a malfunction
D	Return gas temp.	-9 ~ 99°C	Actual testing value. Error code P4 will be shown in case of a malfunction
E	Ambient temp.	-9 ~ 99°C	Actual testing value. Error code P5 will be shown in case of a malfunction
F	Electronic expansion valve step	10 ~ 47 step	N*10 step
H	Temp of solar thermal collector	0-140°C	Measured value, if failure, show P6
P	Output voltage of electrical anode	0-5	Actual=display value x 10

Malfunctioning of the unit and error codes

When an error occurs or the protection mode is set automatically, the circuit board and the wired controller will both display the error message.

Protection/ Malfunction	Error code	Possible reasons	Corrective actions
Standby			
Normal running			
Lower tank water temp. sensor failure	P1	1) The sensor open circuit 2) The sensor short circuit 3)PCB board failure	1) Check the sensor connection 2) Replace the sensor 3)change the PCB board
Upper tank water temp. sensor failure	P2	1) The sensor open circuit 2) The sensor short circuit 3) PCB board failure	1) Check the sensor connection 2) Replace the sensor 3) change the PCB board
Evaporator coil temp. sensor failure	P3	1) The sensor open circuit 2) The sensor short circuit 3) PCB board failure	1) Check the sensor connection 2) Replace the sensor 3) change the PCB board
Return air temp sensor failure	P4	1) The sensor open circuit 2) The sensor short circuit 3) PCB board failure	1) Check the sensor connection 2) Replace the sensor 3) change the PCB board
Ambient temp. sensor failure	P5	1) The sensor open circuit 2) The sensor short circuit 3) PCB board failure	1) Check the sensor connection 2) Replace the sensor 3) change the PCB board
Solar temp. sensor failure	P6	1) The sensor open circuit 2) The sensor short circuit	1) Check the sensor connection 2) Replace the sensor

		3) PCB board failure	3) change the PCB board
Electronic anode output open or short circuit	P7	1) Lack of tank water 2) Circuit of electronic anode is open or short 3) PCB board failure	1) Fill the tank with water 2) Connect the circuit well or replace an electronic anode 3) Replace a PCB board
Electronic anode output voltage exceeds normal working range	P8	1) The water quality is abnormal 2) Lack of tank water 3) Circuit of electronic anode is open or short 4) PCB board failure	1) Install water purifying plant to improve the water quality 2) Fill the tank with water 3) Connect the circuit well or replace an electronic anode 1) 4) Replace a PCB board
Emergency switch off	EC	1) Connecting wire off 2) PCB board failure	1) According to the physical truth judging whether is normal or not 2) change the PCB board
High pressure protection (HP Switch)	E1	1) Too high air inlet temp 2) Less water in the tank 3) The electronic expansion valve assembly blocked 4) Too much refrigerant 5) The switch damaged 6) The uncompressed gas is in refrigerant system 7) PCB board failure	1) Check if the air inlet temp is over the working limited 2) Check if the tank is full of water. If not, charge water 3) Replace the electronic expansion valve assembly 4) Discharge some refrigerant 5) Replace a new switch 6) Discharge and then recharge the refrigerant 7) change the PCB board
Low pressure protection (LP Switch)	E2	1) Too low air inlet temp 2) The electronic expansion valve assembly blocked 3) Too less refrigerant 4) The switch damaged 5) The fan assembly can not work 6) PCB board failure	1) Check if the air inlet temp is over the working limited 2) Replace the electronic expansion valve assembly 3) Charge some refrigerant 4) Replace a new switch 5) Check if the fan working when the compressor working. If not, some problems with the fan assembly 6) change the PCB board
Over heat protection (HTP Switch)	E3	1) Too high tank water temp 2) The switch damaged 3) PCB board failure	1) If the tank water temp is over 85C, the switch will open and the unit will stop for protection. After the water comes to normal temp, 2) Replace a new switch 3) Change the PCB board

Solar thermal collector high tem protection	E4	<ol style="list-style-type: none"> 1) solar water circuit water flow very little or without water flow 2) Related connecting wires off 3) Water pump failure 4) PCB board failure 	<ol style="list-style-type: none"> 1) Solar water circuit fluid infusion and exhaust 2) Related connecting wires being reconnected 3) Change the water pump 4) change the PCB board
Water flow failure	E5	<ol style="list-style-type: none"> 1) solar water circuit water flow very little or without water flow 2) Related connecting wires off 3) water pump failure 4) water flow switch failure 5) PCB board failure 	<ol style="list-style-type: none"> 1) Solar water circuit fluid infusion and exhaust 2) Related connecting wires being reconnected 3) Change the water pump 4) Change the water flow switch 5) Change the PCB board
Defrost	Defrosting indicate		
Communication failure	E8		

MAINTENANCE

Maintenance activities

In order to ensure an optimum operation of the unit, a number of checks and inspections on the unit and the field wiring have to be carried out at regular intervals, preferably yearly.

- Check the water supply and air vent frequently, to avoid lack of water or air in the water loop.
- Clean the water filter to keep a good water quality. Lack of water and dirty water can damage the unit.
- Keep the unit in a place where it is dry and clean, and which has good ventilation. Clean the heat exchanger every one to two months.
- Check each part of the unit and the pressure of the system. Replace the defect part if there is any, and recharge the refrigerant if it is required.
- Check the power supply and the electrical system, make sure the electrical components are good, and the wiring is well. If there is a damaged part or a strange smell, please replace it in time.
- If the heat pump is not used for a long time, please drain out all the water from the unit and seal the unit to keep it good. Please drain the water from the lowest point of the boiler to avoid freezing in winter. Water recharge and full inspection on the heat pump is required before it is restarted.
- Do not turn the power 'OFF' when you use the unit continuously, or the water in the pipe will

freeze and split the pipe.

- Keep the unit clean by means of soft damp cloth, no maintenance is required by the operator.
- It is recommended to clean the tank and e-heater regularly to keep an efficient performance.
- It is recommended to set a lower temperature to decrease the heat release, prevent scale and save energy if the outlet water is sufficient.
- Clean the air filter regularly to keep an efficient performance.

TROUBLESHOOTING

This section provides useful information for diagnosing and correcting certain troubles which may occur. Before starting the troubleshooting procedure, carry out a thorough visual inspection of the unit and look for obvious defects such as loose connections or defective wiring.

Before contacting your local dealer, read this chapter carefully, it will save you time and money.



WHEN CARRYING OUT AN INSPECTION ON THE SWITCH BOX OF THE UNIT, ALWAYS MAKE SURE THAT THE MAIN SWITCH OF THE UNIT IS SWITCHED 'OFF'.

The guidelines below might help to solve your problem. If you cannot solve the problem, consult your installer/local dealer.

- No image on the controller (blank display). Check if the main power is still connected.
- One of the error codes appears, consult your local dealer.
- The scheduled timer does work but the programmed actions are executed at the wrong time (e.g. 1 hour too late or too early). Check if the clock and the day of the week are set correctly, adjust if necessary.

ENVIRONMENTAL INFORMATION

This equipment contains fluorinated greenhouse gases covered by the Kyoto Protocol. It should only be serviced or dismantled by professional trained personnel.

This equipment contains R290 refrigerant in the amount as stated in the specification. Do not vent R290 into the atmosphere: R290 is a fluorinated greenhouse gas with a Global Warming Potential (GWP) =3.

DISPOSAL REQUIREMENTS

Dismantling of the unit, treatment of the refrigerant, of oil and of other parts must be done in accordance with relevant local and national legislation.



Your product is marked with this symbol. This means that electrical and electronic products shall not be mixed with unsorted household waste.

Do not try to dismantle the system yourself: the dismantling of the system, treatment of the refrigerant, of oil and other parts must be done by a qualified installer in accordance with relevant

local and national legislation.

Units must be treated at a specialized treatment facility for re-use, recycling and recovery. By ensuring that this product is disposed off correctly, you will help to prevent potential negative consequences for the environment and human health. Please contact the installer or local authority for more information.

WIRING DIAGRAM

Please refer to the wiring diagram on the electric box.

With Solar coil

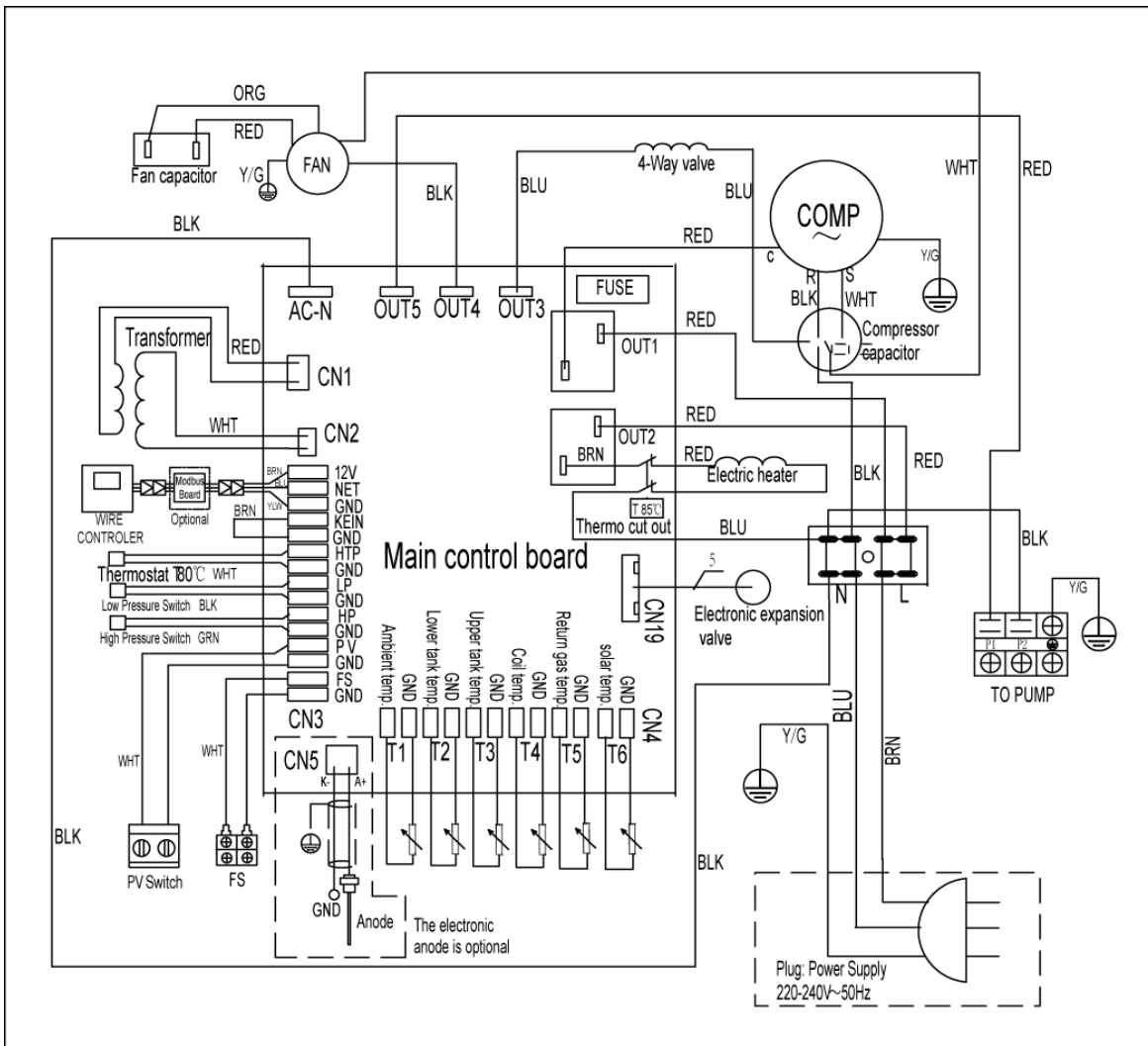

Without Solar coil

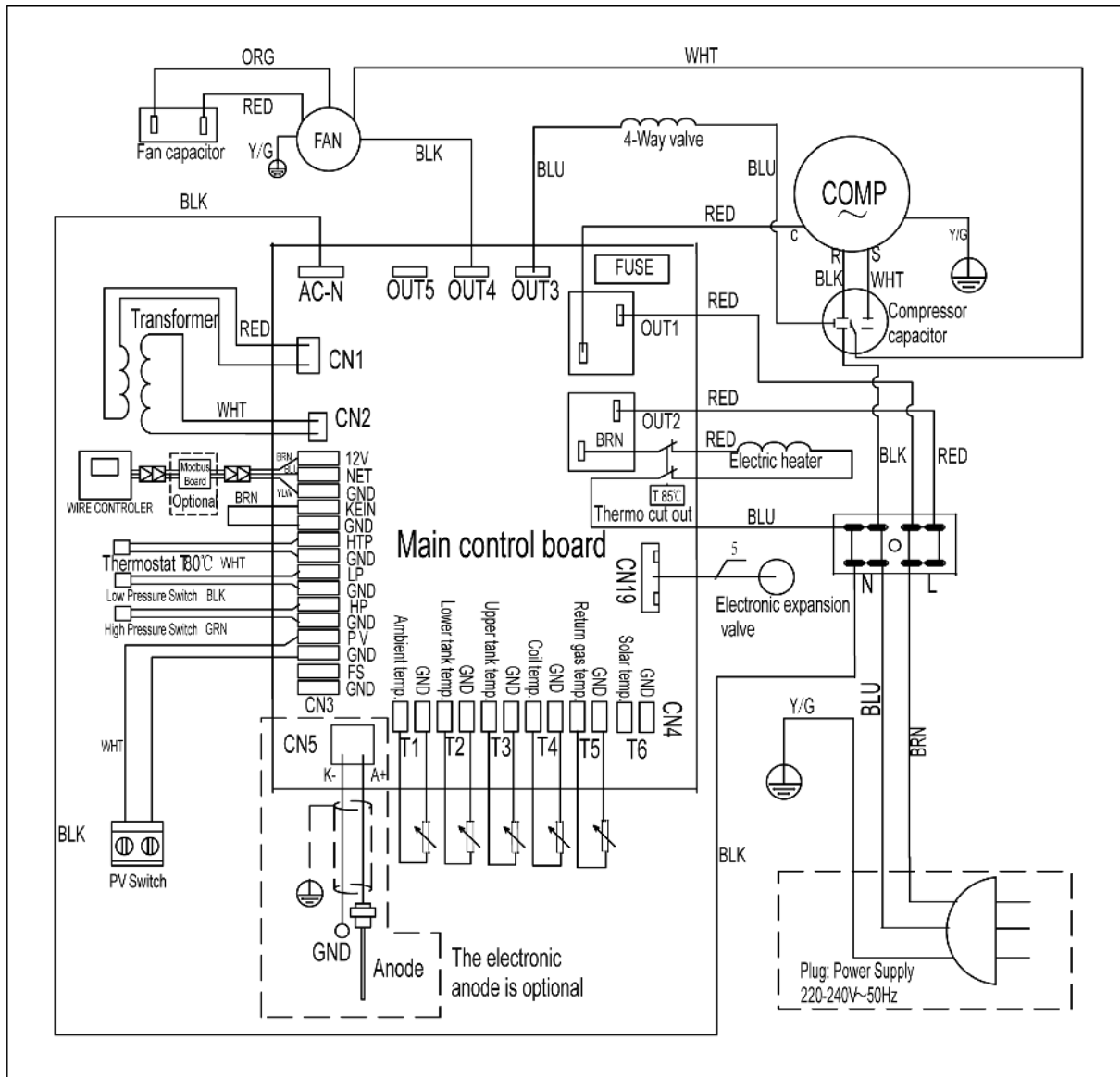

TECHNICAL SPECIFICATION

TECHNICAL DATA (Fjord-1-16/***)		200L	300L
Power supply	V/Ph/Hz	220~240V/1/50Hz	
Water tank Volume	L	200	300
Max power input	W	600+1500 (e-heater)	
Max current	A	2.61+6.8 (e-heater)	
Max.outlet water temperature range(without using E-heater)	°C	60	
Max. water temperature	°C	70	
Min. water temperature	°C	10	
Ambient working temp.	°C	-5~43	
Max. discharge pressure	bar	26	
Min. suction pressure	bar	10	
Refrigerant type		R290	
Compressor	Type	Rotary	
	Brand	GMCC	
	Model	RDSN82V11TZE	
Fan motor	Type	Asynchronous motor	
	W	60	
	RPM	1130	
Air flow	m ³ /h	350	
Duct diameter	mm	177 (Fit flexible 180/200mm duct)	
Max allowed pressure of tank	bar	10	
Inside body material of tank		SUS 304/SUS 316L/2205	
Auxiliary electrical heater	kW	1.5	
Electronic expansion valve		yes	
Anti-corrosion type		Optional (Magnesium stick/Electrical anod anti-corrosion system)	
Solar heat exchanger		Optional (SUS 304/SUS 316L ~ 1m ²)	
Hot water outlet	inch	G 3 / 4	
Solar heat source inlet/outlet	inch	G 3 / 4	
Cold water inlet	inch	G 3 / 4	
Drainage	inch	G 3 / 4	
Condensed water outlet	inch	G 1 / 2	
Heat pump heat exchanger material		Microchannel heat exchanger(Aluminium alloy)	
Net Dimensions		φ560x1750	φ640x1850
Packing Dimensions		629x629x1892	695x695x1989
Net Weight		90	110
Weight with full water		290	410
Gross Weight		100	120