

ADLÅR



SAFETY INSTRUCTIONS

FOR COMPETENT APPROVED PERSONS

Adlår Heat Pumps

6 | 10 | 14 KW

1 CONTENTS

1	CONTENTS	2
2	SAFETY	3
2.1	Action Related Warnings	3
2.2	Qualification Risk	3
2.3	General	3
2.3.1	Danger from improper operation	3
2.3.2	Risk of death from electric shock	3
2.3.3	Risk of death due to lack of safety	4
2.3.4	Risk of being scalded by hot water	4
2.3.5	Risk of injury or material damage due to incorrect handling of the product	4
2.3.6	Risk of material damage due to additional elements in the heating water	4
2.3.7	Risk of material damage caused by using an unsuitable tool	4
2.3.8	Additional General Warnings	4
2.4	REFRIDGERANT	5
2.4.1	Environmental consideration	5
2.4.2	General Avoidance Protocol	6
2.4.3	General Operation Protocol	6
2.4.4	Checks on the refrigeration equipment	7
2.4.5	Controls on electrical appliances	7
2.4.6	Sealed component repairs:	7
2.4.7	Cabling	8
2.4.8	Detection of flammable refrigerants	8
2.4.9	Leak Detection Methods	8
2.4.10	Removal and Emptying	8
2.4.11	Filling Procedures	8
2.4.12	Dismantling	8
2.4.13	Labelling	9
2.4.14	Recovery	9
2.5	Directives	9
2.5.1	Approvals	10
2.5.2	Local Regulations - MCS	10
2.6	REGULATIONS	10
2.6.1	Statutory requirements	10
2.6.2	Standards	10
2.6.3	Reminder of existing regulatory acts	10
2.7	OTHER REGULATIONS	10
2.7.1	Control of Substances Hazardous to Health	10
2.8	RESPONSIBILITIES	10
3	DOCUMENT NOTES	11
3.1	Observing other applicable documents	11
3.2	Storing documents	11
3.3	Applicability of the instructions	11
4	SYSTEM OVERVIEW	12
4.1	Safety devices	12
4.2	Design of the heat pump system	12
4.3	Application limits	12
4.4	Labels Positioning	13
4.4.1	Bar code processing	13
5	Preparation	14
5.1	Lifting the product	14
5.1.1	Risk of injury	14
5.2	Transport	14
5.2.1	Risk of Material Damage	14
5.2.2	Cylinder 45 DEGREE ANGLE	14
5.3	Location Preparation	15
5.3.1	AIR FLOW clearances	15
5.3.2	GROUND PREPARATIONS	15
5.3.3	HeAT PUMP MOUNTING	16
5.3.4	Alignment	16
5.3.5	Site Selection	17
5.4	Electrical	18
5.4.1	Electric Shock Warning	18
5.4.2	Conection Notes	18
5.4.3	Material Damage	18
5.4.4	Risk of Malfunction	18
5.4.5	Establishing the Power Supply	18
6	Operation	19
6.1.1	Risk of Material damage	19
7	Maintenance	19
7.1	General	19
7.1.1	Risk of Injury	19
7.1.2	Observing maintenance intervals	19
7.1.3	Procuring spare parts	19
7.1.4	Instructions before carrying out maintenance work	19
7.2	Cleaning	19
7.2.1	Sharp Edges	19
7.2.2	Process	19
7.3	Risk of Freezing	19
7.4	Refridgerant maintenance	19
7.4.1	Risk of Suffocation	20
7.5	Service	20
7.6	Decommissioning	20
7.6.1	Temporary decommissioning	20
7.6.2	Permanently decommissioning	20
7.7	Disposal	20
7.7.1	Recycling and disposal OF HARDWARE	20
7.7.2	Disposal of Coolant	21
7.7.3	Environmental Damage	21
8	COPYRIGHT & DISCLAIMER	21

2 SAFETY

Our heat pump is constantly being developed, with additional instructions and/or information being processed in the most up-to-date version. The most current version of this document can be requested via info@adlar.co.uk.

Make sure you have read this "Installation Manual" before using our heat pump and keep it for future reference.

2.1 ACTION RELATED WARNINGS

Classification of action-related warnings

The action-related warnings are classified in accordance with the severity of the possible danger using the following warning signs and signal words:



WARNING

Incorrect operation can have serious consequences, such as death, serious injury or major accidents.



ATTENTION

Improper operation may lead to a safety accident, damage to the heat pump or impact the function of the heat pump.



Flammable



Read Carefully



Professional Recycling

2.2 QUALIFICATION RISK

The following work must only be carried out by competent persons who are approved by Adlar and are sufficiently qualified in:

- Installation
 - Disassembly
 - Installation
 - Start-up
 - Maintenance
 - Repair
 - Decommissioning
- Observe all instructions that are included with the product.
 - Proceed in accordance with the current state of technology.
Observe all applicable directives, standards, laws and other regulations.

2.3 GENERAL

2.3.1 DANGER FROM IMPROPER OPERATION

Improper operation may present a danger to you and others, and potentially cause material damage to the heat pump.

- Carefully read the enclosed instructions and all other applicable documents, particularly the "Safety" section and the warnings.
- Only carry out the activities for which instructions are provided in these operating instructions.

2.3.2 RISK OF DEATH FROM ELECTRIC SHOCK

There is a risk of death from electric shock if you touch live components. Before commencing work:

- Disconnect the product from the power supply by switching off all power supplies (electrical partition with a contact opening of at least 3 mm, e.g. fuse or line protection switch).
- Secure against being switched back on again.

- Wait for at least 3 minutes until the capacitors have discharged.
- Check that there is no voltage.

The device must be electrically protected by means of an earth leakage circuit breaker and an automatic circuit breaker or a combination of these (earth leakage circuit breaker).

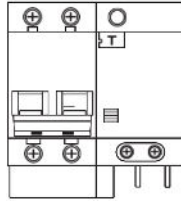

Ensure electrical components are properly connected. If the wiring is not safe, it may cause electric shock, short circuit, heat, or fire.

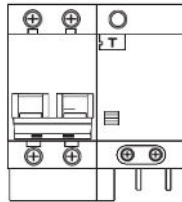

Never operate with a wet hand.

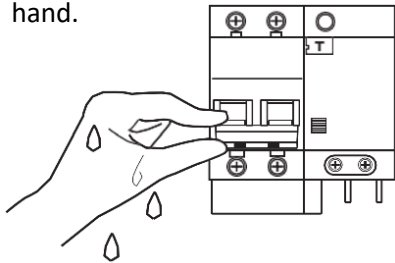

To avoid risk of electric shock or electrocution, do not spray water or other liquids on the heat pump.

2.3.3 RISK OF DEATH DUE TO LACK OF SAFETY

The schematic drawings included in this document do not show all safety devices required for correct installation.

- Install the necessary safety devices in the system.
- Observe the applicable national and international laws, standards and guidelines.

2.3.4 RISK OF BEING SCALDED BY HOT WATER

There is a risk of scalding at the hot water draw-off points if the hot water temperatures are greater than 50 °C. Young children and elderly persons are particularly at risk, even at lower temperatures.

- Select a temperature so that nobody is at risk.

2.3.5 RISK OF INJURY OR MATERIAL DAMAGE DUE TO INCORRECT HANDLING OF THE PRODUCT

Using part of the external or internal structure not specifically designed as handles may lead to injuries (due to falling) or to material damage.

- ONLY use the handles to manoeuvre the product

2.3.6 RISK OF MATERIAL DAMAGE DUE TO ADDITIONAL ELEMENTS IN THE HEATING WATER

Unsuitable frost and corrosion protection agents may damage seals and other components of the heating circuit and may therefore also lead to leaks in the water outlet.

- Only add approved frost and corrosion protection agents to the heating water.

2.3.7 RISK OF MATERIAL DAMAGE CAUSED BY USING AN UNSUITABLE TOOL

- Use the correct tool for all operations, especially paying special attention to tightening or loosening screw connections.

2.3.8 ADDITIONAL GENERAL WARNINGS



GENERAL WARNINGS

1. The heat pump may not be dismantled without professional guidance. Improper disassembly can cause accidents or damage to the heat pump.

2. Do not use or store flammable liquids such as paint, gasoline, alcohol, etc. around the heat pump or near it. Such liquids can cause a fire hazard.
 3. The main (operating) switch of the heat pump must be mounted in such a way that repeated operation of the switch by people, for example children, is prevented. Power switching of the heat pump can cause damage..
 4. The heat pump must be provided with an earth wire. Do not connect the ground wire to the gas pipe, water pipe, lightning rod, etc. The heat pump must be reliably grounded to prevent electric shock.
 5. Never disconnect the power supply when the heat pump is in operation. This can cause damage.
 6. When the heat pump is not used for a long time, turn off the main (mains) switch to avoid accidents.
 7. The heat pump must never be switched off completely in an environment with a temperature below 0 °C. When it is out of use for a long time due to a power failure or other circumstances, it is recommended to drain the system water and switch off the power supply.
3. Various sources with strong electromagnetic radiation can cause an effect on the heat pump. Turn off the power supply and restart the device when affected.
 4. The connected water circuit must be stable and free of air. Weak flow or air in the system can damage to the heat pump.
 5. Do not restart the heat pump regularly. This can damage the heat pump.
 6. The operating parameters of the heat pump and the set values of the protection device are selected by the manufacturer. Users should not change the set values or change the wiring connections. Such actions may damage the heat pump.
 7. It is necessary to carry out regular maintenance on the heat pump in accordance with the instructions. Good maintenance is essential to ensure that the heat pump continues to function properly.



ATTENTION

1. Never put your hands or other objects in the ventilation area of the heat pump when the fan is running as it can cause serious injury. Objects in the ventilation area can cause damage to the heat pump.
2. The fan cover must never be removed when the heat pump is in operation or when it can be switched on (automatically) (service work by expert personnel excluded). When the fan is running it can cause serious injury.

NEVER insert fingers or other objects into the ventilation section.

! DANGER

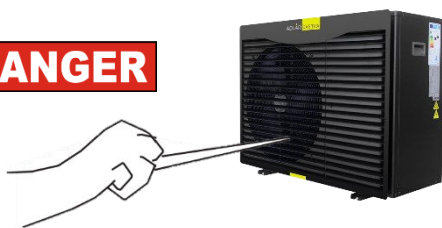

2.4 REFRIDGERANT

2.4.1 ENVIRONMENTAL CONSIDERATION

The heat pump contains R32 coolant. The coolant must not be allowed to escape into the atmosphere. R32 is a fluorinated greenhouse gas covered by the Kyoto Protocol, with a GWP of 1725 (GWP = Global Warming Potential). If it escapes into the atmosphere, its impact is 1725 times stronger than the natural greenhouse gas CO₂.

Before the heat pump is disposed of, the coolant it contains must be completely drained into a suitable vessel so that it can then be recycled or disposed of in accordance with the regulations.

- Ensure that only officially certified competent persons with appropriate protective equipment carry out maintenance work on the coolant circuit or access it.
- Arrange for the coolant contained in the product to be recycled or disposed of by accredited specialists in accordance with regulations.
- Only use coolant R32
- Only use a suitable R32 tool for the filling, pressure measurement, vacuum generation and discharge.

- Solder the lines using shielding gas. Check the lines for leak-tightness using nitrogen.
- In the event of a repair or maintenance work, fill the coolant circuit with liquid coolant.
- If the coolant circuit is not leak-tight, check which component must be repaired or replaced.
- Lower the negative pressure in the coolant circuit to max. 10 mbar (1000 Pa).
- When filling the coolant circuit, observe the values in the "Technical data" section.

2.4.2 GENERAL AVOIDANCE PROTOCOL

1. Do not use any means to speed up the defrosting process or clean the heat pump other than those recommended by the manufacturer.
2. The appliance must be stored in an area without continuously operating sources of flammable machinery (for example open flames, an operating gas appliance, or an electric heater).
3. Do not pierce or burn refrigerant tubes.
4. Please note that refrigerants may not contain odour.
5. Maintenance should only be performed as recommended by the manufacturer.
6. The heat pump must be stored in a well-ventilated area.
7. All work procedures that affect the safety of the equipment may only be carried out by authorized persons.

2.4.3 GENERAL OPERATION PROTOCOL

1. Transport of equipment containing flammable refrigerants: Compliance with transport regulations.
2. Equipment Marking Using Signs: Compliance with local laws & regulations
3. Disposal of equipment with flammable refrigerants: Compliance with local laws & regulations
4. Storage of equipment/devices: Storage of equipment should be in accordance with the manufacturer's instructions.
5. Storage of packaged (unsold) equipment: The protection of the storage packaging must be constructed in such a way that mechanical

damage to the equipment in the storage packaging will not cause leakage of the refrigerant. The maximum number of devices that may be stored together is determined by applicable laws and regulations

6. Maintenance information:

6.1 General Working Conditions

Before starting work on systems containing flammable refrigerants, safety checks are necessary to ensure that the risk of ignition is minimised. For repairs to the cooling system, the precautions must be taken before carrying out any work on the system.

6.2 Working procedure

All work must be carried out according to a controlled procedure, in order to minimize the risk of flammable gas or vapor during the execution of the work.

6.3 General work area

All maintenance personnel and other personnel working in the area are instructed on how to carry out the work. Work in confined spaces should be avoided. The area around the work area must be cordoned off. Make sure the conditions in the work area are safe by checking for flammable material.

6.4 Check for the presence of refrigerant

The area should be checked with a suitable refrigerant detector before and during work to ensure that the technician is aware of a potentially flammable atmosphere. Ensure that the leak detection equipment used is suitable for use with flammable refrigerants, i.e. non-sparking, adequately sealed or intrinsically safe.

6.5 Presence of fire extinguisher

If hot work has to be carried out on the refrigeration equipment or on the associated parts, suitable fire extinguishing equipment must be available. Have a dry powder or CO₂ fire extinguisher at the work area.

6.6 No ignition sources

No one who performs work on a refrigeration system, where pipes are exposed that contain or have contained flammable refrigerants, may use sources of ignition in such a way that this can lead to a risk of fire or explosion. All possible sources of ignition, including cigarette smoking, must be kept sufficiently far from the place of installation, repair and disposal where flammable refrigerant may be released into the surrounding area. Before work takes place, the area around the equipment should be surveyed to ensure

there are no flammable hazards or ignition risks. Signs with the inscription "No Smoking" must also be posted.

6.7 Ventilated space

Ensure that the work area is in the open air or adequately ventilated before starting work in the system or when performing hot work. A certain degree of ventilation must be continued during the period that the work is carried out. Ventilation must safely disperse any released refrigerant and preferably expel it externally into the atmosphere.

2.4.4 CHECKS ON THE REFRIGERATION EQUIPMENT

When electrical parts are replaced, they must be fit for purpose and conform to the correct specification(s). The manufacturer's maintenance and service guidelines should be followed at all times. If in doubt, consult the manufacturer's technical department for assistance.

The following controls are applied to installations using flammable refrigerants:

- The charge size is in accordance with the size of the room in which the refrigerant with parts is installed;
- The ventilation machines and outlets work properly and are not obstructed;
- If an indirect refrigerant circuit is used, the secondary circuit must be checked for the presence of refrigerant;
- Marking of the equipment remains visible and legible. Unreadable markings and characters should be corrected;
- Refrigerant piping or components shall be installed where it is unlikely that they will be exposed to a substance capable of attacking refrigerant containing components, unless the components are made of materials that are inherently resistant to corrosion or are suitably protected against corrosion.

2.4.5 CONTROLS ON ELECTRICAL APPLIANCES

Repair and maintenance of electrical components includes initial safety checks and component inspection procedures. If a fault occurs which could compromise safety, no electrical supply should be

connected to the circuit until it has been satisfactorily resolved. If the error cannot be corrected immediately, but it is necessary to continue operation, an adequate workaround should be used. This should be reported to the owner of the equipment so that all parties are notified.

Initial security checks include:

- That the capacitor is discharged: this must be done in a safe way to avoid possible sparks;
- That no live electrical components and wiring are exposed during filling, repair or cleaning of the system;
- That the heat pump remains earthed.

2.4.6 SEALED COMPONENT REPAIRS:

- During repairs to sealed parts, all electrical components related to the equipment being worked on must be disconnected before removing the sealed covers. If it is absolutely necessary to have an electrical supply to the equipment during operation, a permanent working leak detector should be fitted at the most critical point to warn of a potentially hazardous situation.
- Particular attention should be paid to the following to ensure that working on electrical parts does not alter the enclosure in such a way as to affect the level of protection. This includes damage to cables, excessive number of connections, terminals not made to original specification, damage to seals, incorrect installation of glands, etc. Ensure that the device is mounted securely. Ensure that seals or sealing materials have not degraded to the point where they no longer serve the purpose of preventing the entry of flammable atmospheres. Replacement parts must be in accordance with the manufacturer's specifications.
- Repair to intrinsically safe components
- Do not apply permanent inductive or capacitance loads to the circuit without ensuring that it does not exceed the voltage rating permitted by the equipment being used. Intrinsically safe components are the only types that can be worked on in the presence of a flammable atmosphere. The test device must have the correct value. Replace parts only with parts specified by the manufacturer. Other parts can

cause the refrigerant to ignite in the event of a leak.

2.4.7 CABLING

Check that the cabling is not subject to wear, corrosion, excessive pressure, vibration, sharp edges or other adverse environmental effects. The check should also take into account the effects of aging or continuous vibration from sources such as compressors or fans.

2.4.8 DETECTION OF FLAMMABLE REFRIGERANTS

Under no circumstances should potential sources of ignition be used when tracing refrigerant leaks. A halide burner (or any other open flame detector) should not be used.

2.4.9 LEAK DETECTION METHODS

The following leak detection methods are considered acceptable for systems containing flammable refrigerants. Electronic leak detectors should be used to detect flammable refrigerants. Please note that its sensitivity may be insufficient and it may need to be recalibrated. (Detection equipment must be used to detect flammable refrigerants. Please note that its sensitivity may be insufficient and it may need to be recalibrated. (Detection equipment must be calibrated in an area without refrigerant). Ensure that the detector is not a potential source of ignition and is suitable for the refrigerant used. Leak detection equipment should be set to a percentage of the LFL (lower flammability limit) of the refrigerant being used and calibrated accordingly. Cleaning agents should be avoided as the chlorine may react with the refrigerant and corrode the copper pipework.

2.4.10 REMOVAL AND EMPTYING

When breaking into the refrigerant circuit to make repairs – or for any other purpose – conventional procedures should be used. However, it is important that the work is carried out very carefully, given the flammability. The following procedure should be followed:

1. Remove refrigerant;
2. Flush the circuit with inert gas;
3. Emptying;
4. Repurge with inert gas;

5. Open the circuit by cutting or soldering.

The refrigerant charge must be recovered in the appropriate recovery cylinders. The system must be "purged" with OFN (oxygen-free nitrogen) to make it safe. This process may need to be repeated several times. Compressed air or oxygen should not be used for this task.

Flushing should be completed by breaking the vacuum in the system with OFN and continuing to fill until working pressure is reached, then venting and finally drawing it to a vacuum. This process is repeated until there is no refrigerant left in the system. When the final OFN charge has been used, the system must be vented to atmospheric pressure to allow work on it. This operation is absolutely necessary in order to carry out soldering work on the pipework. Make sure that the exhaust for the vacuum pump is not near sources of ignition and that adequate ventilation is available.

2.4.11 FILLING PROCEDURES

In addition to conventional filling procedures, the following requirements must be followed:

1. Ensure that contamination by various refrigerants does not occur when using filling equipment. Hoses or lines should be as short as possible due to the amount of refrigerant they contain.
2. Cylinders must be kept upright.
3. Make sure the refrigeration system is grounded before charging the system with refrigerant.
4. When charging is complete, label the system (if not already).
5. Extreme care should be taken not to overfill the cooling system.
6. Before filling the system, it should be pressure tested with OFN (oxygen-free nitrogen). The system should also be leak tested after filling is complete, prior to commissioning. A follow-up leak test must be performed before leaving the site.

2.4.12 DISMANTLING

Before performing this procedure, it is essential that the technician is thoroughly familiar with the equipment and all its details. It is recommended to safely recover all refrigerants. An oil and refrigerant sample must be taken (if analysis is required) before these operations are carried out and before the

reclaimed refrigerant is used again. It is essential that the power supply is available before work is started.

1. Become familiar with the equipment and its operation.
2. Electrically isolate the system.
3. Before starting the procedure, make sure that:
 1. Required equipment and tools are available;
 2. All personal protective equipment is available and used correctly;
 3. The recovery process is supervised at all times by an authorized person;
 4. Recovery equipment and cylinders meet the appropriate standards.
5. Pump down the coolant system, if possible.
6. If a vacuum is not possible, create a manifold so that refrigerant can be removed from different parts of the system.
7. Make sure the cylinder is on the scale before recovery.
8. Start the equipment and operate according to the manufacturer's instructions.
9. Do not fill cylinders more than 80% volume of liquid charge.
10. Do not exceed the maximum working pressure of the cylinder, even temporarily.
11. When the cylinders are properly filled and the process is complete, ensure that the cylinders and equipment are immediately removed from the work area and that all safety valves on the equipment are closed.
12. Recovered refrigerant should not be charged into another refrigeration system unless it has been cleaned and checked.

2.4.13 LABELLING

The equipment must be marked that it has been taken out of service and has been drained of refrigerant. The label is dated and signed. Make sure there are labels on the equipment indicating that the equipment contains a flammable refrigerant.

2.4.14 RECOVERY

When removing refrigerants from a system, either for maintenance or decommissioning, it is recommended to safely remove all refrigerants. When transferring refrigerant in cylinders, ensure that only suitable refrigerant recovery cylinders are used. Ensure that the correct number of cylinders to hold the total

system charge are available. All cylinders to be used are dedicated to the reclaimed refrigerant and labelled for that refrigerant (i.e. special refrigerant recovery cylinders). Cylinders must be complete with a pressure relief valve and associated shut-off valves in good condition. Empty recovery cylinders are removed and, if possible, refrigerated before recovery. The recovery equipment must be in good working order or provided with the necessary instructions and must be suitable for the recovery of flammable refrigerants. In addition, a set of properly functioning and calibrated scales must be available.

Hoses must be complete with leak-free disconnect couplings and in good condition. Before using the recovery machine, verify that it is in satisfactory condition, has been properly maintained and that all associated electrical components are sealed to prevent ignition in the event of a refrigerant release. If in doubt, ask the manufacturer.

The recovered refrigerant will be returned to the refrigerant supplier in the correct cylinder and will be labelled with the correct relevant information. Do not mix refrigerants in recovery equipment, especially cylinders. When compressors or compressor oils are removed, make sure they are removed to an acceptable level to ensure that flammable refrigerant is not left in the lubricant. The emptying process must be carried out before the compressor is returned to the supplier. Only the electrical heating of the compressor housing should be used to speed up this process. When oil is drained from a system, it must be done safely.

2.5 DIRECTIVES

- Observe the national regulations, standards, guidelines and laws.

2.4.2 CE UKCA label



The CE and UKCA label shows that the products comply with the basic requirements of the applicable directives as stated on the identification plate. The declaration of conformity can be viewed at the manufacturer's site.

2.5.1 APPROVALS

This product has been fully tested in accordance with:
– BS EN 14511:2011

2.5.2 LOCAL REGULATIONS - MCS



MCS places responsibilities on both manufacturers and installers. The purpose is to ensure that customers are provided with the correct equipment for their needs, that it is installed, commissioned and serviced in accordance with the manufacturer's instructions by a competent person approved at the time by the Health and Safety Executive and that it meets the requirements of the appropriate Building Regulations.

The MCS Checklist can be used to demonstrate compliance with Building Regulations and should be provided to the customer for future reference. Installers are required to carry out installation, commissioning and servicing work in accordance with the MCS standards of Practice Safety.

Visit www.centralheating.co.uk for more information. Planning consent and Building works notification should be submitted either to Building Control or to a Competent Person Provider.

2.6 REGULATIONS

2.6.1 STATUTORY REQUIREMENTS

Where no British Standards exists, materials and equipment should be fit for their purpose and of suitable quality and workmanship.

The installation of this appliance must be carried out by a competent person in accordance the rules in force in the countries of destination.

Manufacturer's instructions must not be taken as overriding statutory requirements.

2.6.2 STANDARDS

On installing and commissioning the appliance you must adhere to the technical rules, standards and provisions in effect at the time.

2.6.3 REMINDER OF EXISTING REGULATORY ACTS

– EC regulation No. 2037/2000 from the 29th of June 2000 This European regulation repeals regulation No. 3093/94 and presents the elimination schedules of CFC and HCFC. It also deals with the collection of refrigerants, system leaks, particularly systems containing more than 3 kg of CFC or HCFC, as well as the minimum level of qualification required by the technicians.

– EC regulation No. 0842/2006 from the 17th of May 2006 regarding the containment, use, collection and disposal of the fluorinated greenhouse gases, the labelling and elimination of the products and equipment containing these gases, the restriction of use and banning of certain products from the market, as well as the training and certification of personnel and companies operating in the activities targeted by this regulation: refrigeration, air-conditioning, heat pumps and fire protection systems containing greenhouse gases.

2.7 OTHER REGULATIONS

2.7.1 CONTROL OF SUBSTANCES HAZARDOUS TO HEALTH

Under Section 6 of The Health and Safety at Work Act 1974, we are required to provide information on substances hazardous to health. The adhesives and sealants used in this appliance are cured and give no known hazard in this state.

The refrigerant used in this appliance is R35 the use of which is strictly controlled by F Gas regulation EN842/2006.

2.8 RESPONSIBILITIES

The manufacturer declines all responsibility and voids the warranty for damage from:

1. Improper installation, including failure to follow the instructions in this manual;
2. Changes or errors in the electric or water connections;
3. Use of the heat pump under conditions other than those specified in the manual.

3 DOCUMENT NOTES

3.1 OBSERVING OTHER APPLICABLE DOCUMENTS

- You must observe all the operating and installation instructions included with the system components.

3.2 STORING DOCUMENTS

- Pass these instructions and all other applicable documents on to the system operator.

3.3 APPLICABILITY OF THE INSTRUCTIONS

These instructions apply to units with the following type designations and article numbers only:

Name	
Aurora II 6kW	006AUR01
Aurora II 10kW	010AUR02
Aurora II 14kW	014AUR02
Aurora II 14kW 3-phase	014-AUR02-3

4 SYSTEM OVERVIEW

4.1 SAFETY DEVICES

- The product can work at the following outside temperatures:

Heating Mode	-15 ... 28 °C
Cylinder Charging Mode	-15 ... 46 °C

- If the product's refrigerant circuit pressure exceeds the maximum pressure of 4.15 MPa (41.5 bar), the high pressure switch switches the product off. Following a waiting period, the product attempts to start once more. After three failed start attempts in succession, a fault message is displayed.
- If the product is switched off, the crankcase housing heating is switched on when the compressor outlet temperature reaches 7 °C in order to prevent possible damage caused by switching it back on.
- If the compressor inlet temperature and the compressor outlet temperature are below 1 °C, the compressor does not start up.
- A temperature sensor on the compressor outlet limits the product's operation if the measured temperature exceeds the maximum permissible temperature. The maximum permissible temperature depends on the evaporation and condensation temperature.
- The product measures the flow rate of the connected heating circuit when starting up the product.
- If the heating circuit temperature falls below 3 °C, the product's frost protection function is automatically activated as the heating pump is started. In addition, frost protection agent should be added to the heating water as the heating water temperature may fall below the freezing point in the event of a power cut, which poses a risk of frost to the heating installation.



ATTENTION

Operating the heat pump outside the application limits results in the heat pump being switched off by the internal control and safety devices.

4.2 DESIGN OF THE HEAT PUMP SYSTEM

The heat pump system consists of the following components:

- AURURA II heat pump
- AI heat pump control module
- Additional hydraulic and electrical components, as required or specified
- Additional mechanical components, as required

The heat pump is predominately controlled by the control module.

4.3 APPLICATION LIMITS

Operation of the pump outside the application limits results in the heat pump being switched off by the internal control and safety devices.

4.4 LABELS POSITIONING



No.	TYPE	POSITION	
01	Warning	Top side in the middle rear, close to the fan	
02	Energy Label	Right side panel	
03	Nameplate	Right side panel	
04	Warning	Back panel top	
05	Barcode	On the packaging carton	
06	Warning	Right side panel	
07	Warning	Right side panel	
08	Indication Labels	Back panel	
09	R32 Symbol	Front panel left top	
10	Manual	Packed inside the unit	

4.4.1 BAR CODE PROCESSING

Two bar codes are attached to the carton packaging. One should be removed and placed in location as defined above, the other bar code should be attached to this document. Finally the bar code details should be recorded with the customer details within the Adlar Customer Database.

5 PREPARATION

5.1 LIFTING THE PRODUCT



5.1.1 RISK OF INJURY

Lifting weights that are too heavy may cause injury to the spine, for example.

- When transporting the product, two people should lift it.
- Observe the product weight stated in the technical data.
- When transporting heavy loads, observe the applicable directives and regulations.



When lifting the unit, the specifically designed handles should be used to manoeuvre the heat pump. Lifting should be done using leg muscles rather than back and arm muscles.



Name	N.W.
Aurora II 6kW	102 kg
Aurora II 10kW	109 kg
Aurora II 14kW	125 kg
Aurora II 14kW 3-phase	124 kg

5.2 TRANSPORT



5.2.1 RISK OF MATERIAL DAMAGE

Regardless of the mode of transport, the heat pump must never be tilted by more than 45°. Otherwise, this may lead to malfunctions in the coolant circuit during subsequent operation. In the worst case scenario, this may lead to a fault in the whole system.

- During transport, do not tilt the heat pump by any more than the maximum angle of 45°.
1. Use the transportation belt to carry the product to the final installation site.
 2. Only lift the product from the back and side where the hydraulic connections are located.
 3. When transporting the product using a hand truck, secure the product using a belt.
 4. In order to avoid scratches and damage, protect the sides of the product that come into contact with the hand truck.

5.2.2 CYLINDER 45 DEGREE ANGLE

With this type of handling, it is advised that the maximum permissible inclination angle of 45 degree is not exceeded. If transport in an inclined position cannot be avoided, the unit should be taken into operation one hour after it has been moved into final position.

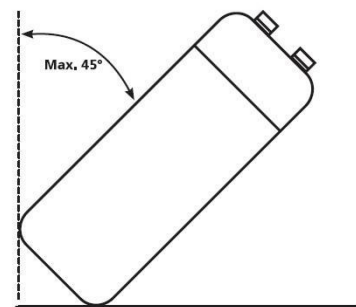

- **ATTENTION: DUE TO THE HIGH CENTER OF GRAVITY, LOW OVERTURNING MOMENT, THE UNIT MUST BE SECURED AGAINST TIPPING OVER.**

5.3 LOCATION PREPARATION

5.3.1 AIR FLOW CLEARANCES

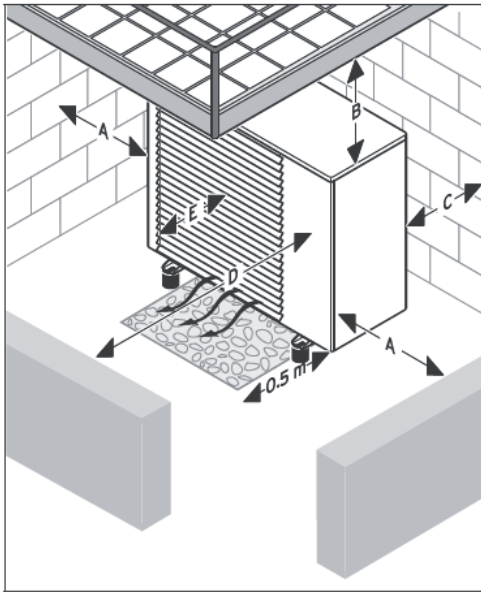

Clearance	Dimension
A	>300 mm
B	> 500 mm
C	> 200 mm*
D	> 600 mm
E	> 300 mm
* Caution: If the minimum clearances are not maintained the efficiency of the product may be affected.	

- To guarantee sufficient air flow and to facilitate maintenance work, observe the minimum clearances that are specified.
- Ensure that there is sufficient room to install the hydraulic lines.
- If the product is to be installed in areas where heavy snow falls, ensure that the snow does not accumulate around the product and that the minimum clearances specified above are observed. If you cannot ensure this, install an additional heat generator in the heating circuit.

5.3.2 GROUND PREPARATIONS

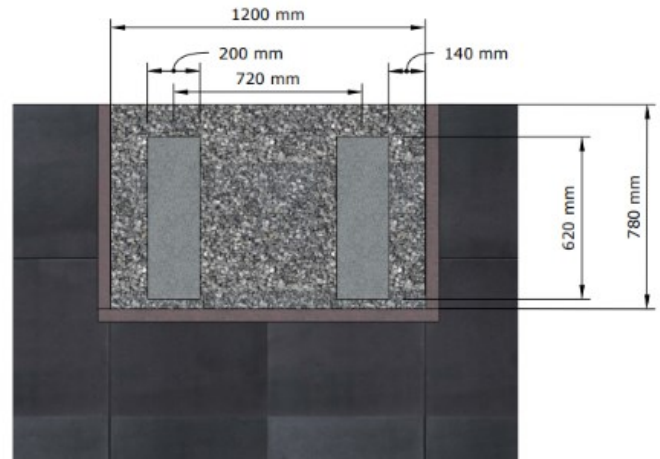
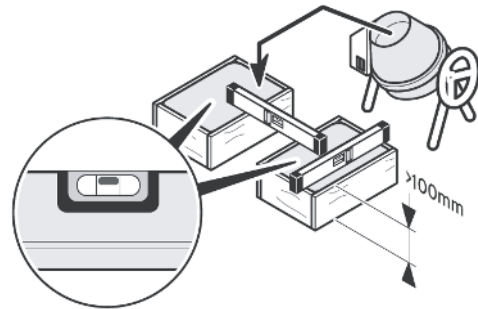

Fig. 1

1. Foundation:

- Install both foundation slabs, ensure they are vertically and horizontally level
- The concrete foundation must not be joined to the house foundation.
- Material: Concrete or plastic/composite



2. Gravel Layer:

- Depth of gravel layer depends on the water permeability. Water must be able to flow freely into the soil layer. (Guideline: When emptying a large filled watering can, the gravel layer must not overflow).
- Recommended depth >0.1m



ICE

Risk of injury due to frozen condensate.

Frozen condensate on paths may cause falls.

- Ensure that condensate does not discharge onto paths and that ice cannot build up there.
- Ensure that no water collects under the product.

In order to avoid ice formation, ensure that the ground in front of the product can absorb water well.

5.3.3 HEAT PUMP MOUNTING

1. Install the heat pump on a solid surface such as concrete, and the load-bearing cover with the support brackets, or a mounting bracket that meets the strength requirements
2. Mount the heat pump on the support brackets and make sure it is level;
3. If the heat pump is installed on a wall or on a roof, the bracket must be fixed firmly enough to prevent damage from natural phenomena or strong winds.
4. The positioning of the outdoor unit should consider all tubes and connections. It is required to install the bottom mounting points in four positions with a bolt size of 10 mm.
5. The heat pump must be installed so that the slope of a vertical surface does not exceed 5 degrees;
6. Do not install the heat pump directly on the ground.
7. The strength of an ordinary air conditioning bracket will often not be sufficient for a monoblock heat pump. Design or select the frame according to weight specifications.
8. If the heat pump is to be installed on an open balcony or roof, it is necessary to use hoisting and/or lifting equipment. Please note the following points for attention:
 - Use four or more soft slings to lift the heat pump;
 - To prevent scratches and/or deformation of the surfaces of the heat pump, a protective plate must be mounted against the relevant surfaces before lifting and loading;
 - Check whether the foundation is correct before installing the heat pump

5.3.4 ALIGNMENT

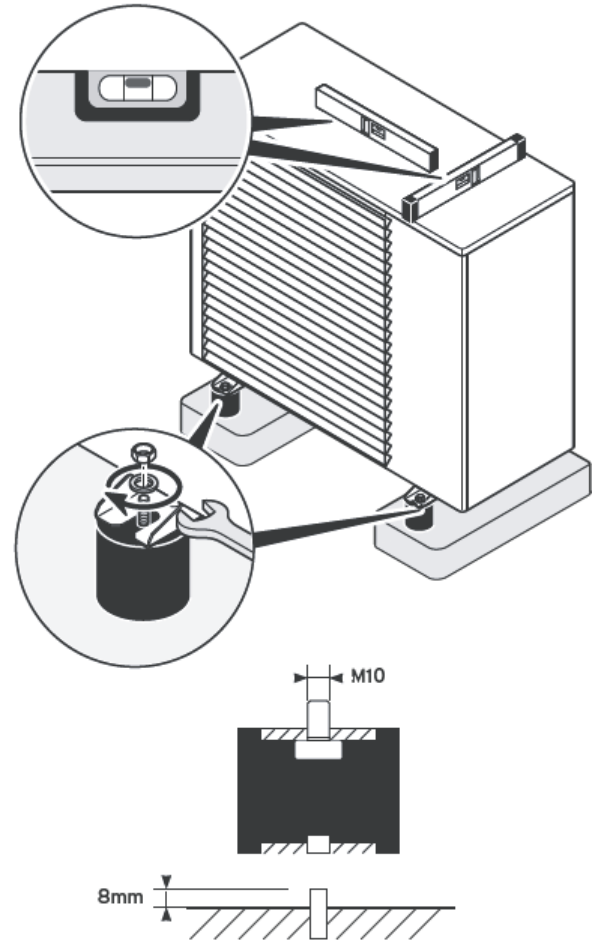

1. Only use bolts of a specific length.
 - Maximum length: ≤ 8 mm
2. Align the product horizontally so that condensate can flow.

Recommended:

It is recommended to install the heat pump with the vibration-isolating feet supplied. The product is lifted by the vibration-isolating feet, which simplifies the condensate-discharge process and reduces vibrations.

3. Screw in the vibration-damping feet using the concrete foundation.

5.3.5 SITE SELECTION

Observe all valid regulations.

- Install the product outside the building.
- Do not install the product:
 1. Near a heat source,
 2. Near flammable materials,
 3. Near ventilation openings for adjacent buildings,
 4. Under deciduous trees.
- Note the following points when installing the product:
 5. Prevailing winds,
 6. The visual impression on the environment
- Avoid places where strong winds blow on the product's air outlet.
- Point the fan away from nearby windows. Install noise p
- Install the product on one of the following supports:
 7. Concrete slab,
 8. Steel T-beam,
 9. Concrete block,
 10. Elevating socket
 11. Wall bracket

Do not expose the product to dusty or corrosive air (e.g. near

- Do not install the product near ventilation shafts.
- Prepare the routing for the electrical lines.



Installation in the following locations may cause the heat pu

1. A place with a lot of oil;
2. Very wet environment
3. Seaside salt-alkali area;
4. Special environmental conditions;
5. With high-frequency facilities such as wireless equip

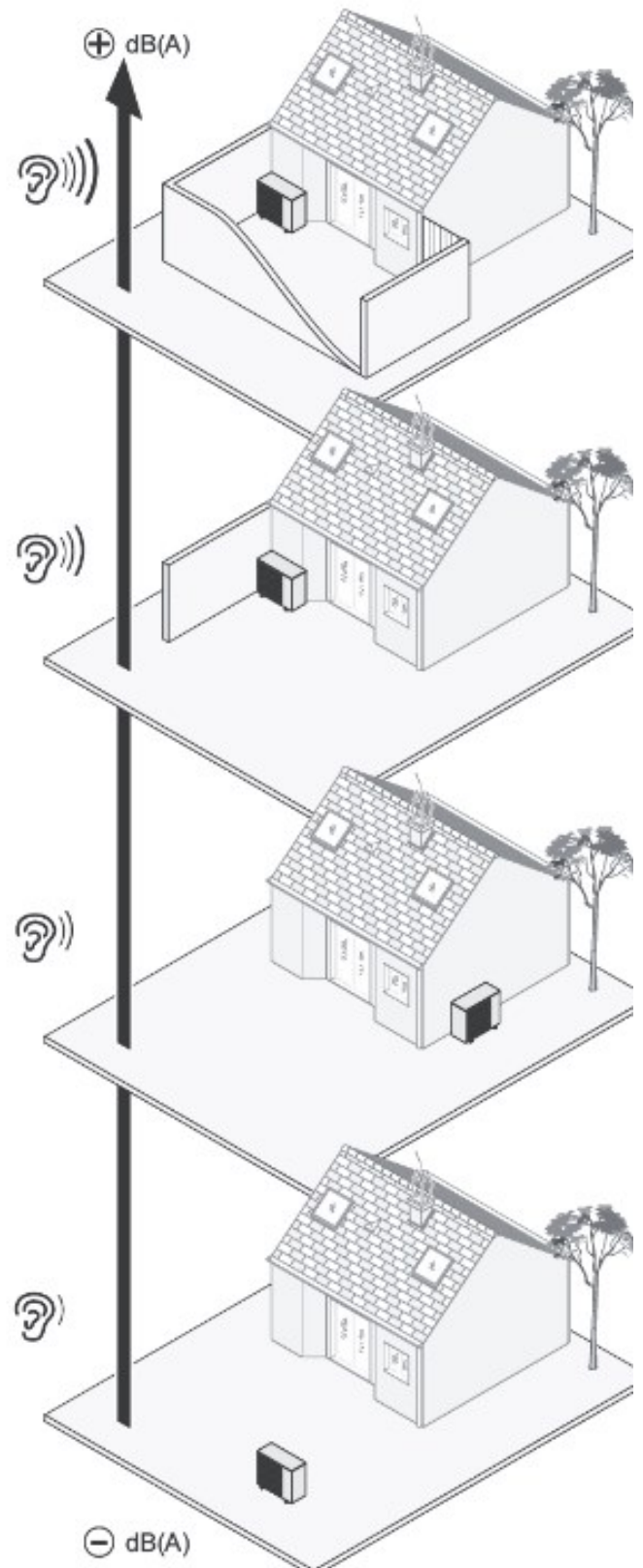

5.4 ELECTRICAL



5.4.1 ELECTRIC SHOCK WARNING

Risk of death from electric shock as a result of an improper electrical connection!

An improper electrical connection may negatively affect the operational safety of the product and result in material damage or personal injury.

- The electrical installation must be carried out by a suitably qualified competent person who is responsible for complying with the existing standards and directives.

Refer to the SAFETY section for further guidance on ensuring live electric power is OFF before starting work.

5.4.2 CONNECTION NOTES

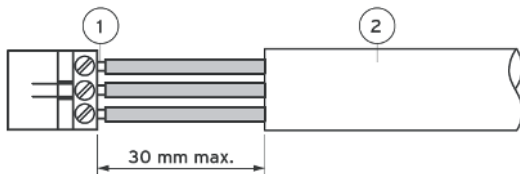

1. Stripped wire 2. Insulation

1. Only strip 3cm from the outer sheathing of flexible lines
2. Secure the conductors in the connection terminals
3. All wiring used must comply with local regulations.
4. The specification table should be carefully checked to ensure that the wiring meets the specified requirements and is correctly wired in accordance with the wiring diagram;
5. The auxiliary electric heater must be equipped with an independent circuit breaker and earth leakage protection device;
6. Wiring must not come into contact with copper pipes, compressors, motors or other operational components;



5.4.3 MATERIAL DAMAGE

At mains voltages greater than 253 V, electronic components may be damaged.

- Ensure that the rated voltage of the mains is 230 V (+10%/-15%) ~ 50 Hz.



5.4.4 RISK OF MALFUNCTION

If the power supply lines are incorrectly installed then power supply may be disrupted and cause damage to the heat pump and electrical circuits.

Do not change the internal wiring of the device without permission. This voids the manufacturer's warranty and responsibility.

AURORA II – 6	
Supply Power	220 ~ 240 V / 1 / 50 Hz
Max Current	12A
Specification	Fuse Characteristic: B Nominal Current: 16A Pole: 1P +N Nominal Fault Current: 30 mA

AURORA II – 10 kW	AURORA II – 14 kW
220 ~ 240 V / 1 / 50	220 ~ 240 V / 1 / 50
17	27,5
B	B
20A	30A
1P +N	1P +N
30 mA	30 mA

5.4.5 ESTABLISHING THE POWER SUPPLY

The external mains connection cable must be earthed and connected with the correct polarity and in accordance with the valid regulations.

- Check that the mains connection cable is connected correctly.
- The cables that connect the product to the fuse box must:
 - Be suitable for fixed installation,
 - Be weatherproof,
 - Be equipped with a wire cross-section that is necessary for the product performance.
- Connect the product using a fixed connection and a partition with a contact opening of at least 3 mm (e.g. fuses or power switches).

- In order to meet the overvoltage category II requirements, further fuse protection may be required.
- To meet the overvoltage category III conditions, the partitions must ensure a complete separation of the power supply.

6 OPERATION



ATTENTION

6.1.1 RISK OF MATERIAL DAMAGE

Using incorrect settings may cause damage to the heating installation

- Only access the installer settings if you are an approved installer.

7 MAINTENANCE

7.1 GENERAL



7.1.1 RISK OF INJURY

Only carry out maintenance work if you are trained to do so, especially when adjusting electrical or coolant parts.

- Escaping coolant may cause freezing if the exit point is touched.
- Avoid skin and eye contact with coolant

7.1.2 OBSERVING MAINTENANCE INTERVALS

1. Only carry out maintenance work if you are a competent person.
2. Carry out annual maintenance.

7.1.3 PROCURING SPARE PARTS

The original components of the unit were also certified as part of the CE declaration of conformity. Information about available Adlar genuine spare parts is available by contacting the contact address provided on the reverse of this document.

- If you require spare parts for maintenance or repair work, use only Adlar genuine spare parts.

7.1.4 INSTRUCTIONS BEFORE CARRYING OUT MAINTENANCE WORK

Observe the basic safety rules before carrying out maintenance work or installing spare parts.

- Switch the system off.
- Disconnect the system from the power supply.
- Where necessary, disconnect the heating circuit from the product by using the stop valves.
- If you have to replace parts on the heating circuit, you must first drain the product.
- When working on the product, protect all electric components from spray water.

7.2 CLEANING

7.2.1 SHARP EDGES

The product's casing sections have sharp edges.



- Wear gloves when installing or dismantling the product's casing sections.

7.2.2 PROCESS

1. Remove the panels
2. Lift off covers
3. Clean the product

7.3 RISK OF FREEZING

If a situation arises in which the outside temperature drops below freezing point and there is no electricity for a long time due to certain circumstances, the heat pump must be shut off by closing the ball valves in both the supply and return pipe (both mounted indoors) and the heat pump must be drained using the drain at the bottom of the heat pump, in order to prevent any risk of the central heating water freezing. Frost protection valves excluded.

7.4 REFRIDGERANT MAINTENANCE

1. The heat pump is equipped with an inspection needle valve on the suction and discharge pipes. The service personnel can connect the pressure

- gauge to check the high and low pressure conditions of the system.
- If the heat pump is charged with refrigerant under operating conditions, the refrigerant should be supplied at the needle valve of the low pressure side. Suppose the refrigerant is added to the suction side. In that case, the refrigerant opening should be small so that the refrigerant in the refrigerant bottle slowly enters the system to prevent liquid from collapsing.
 - Detection of refrigerant leakage Check whether there is leakage at the connections by means of soapy water or a refrigerant leak detector. When a refrigerant leak occurs, the leak point must be found and repaired. Make sure that no refrigerant or additional pressures remain in the system when the leak is repaired. In such a case, an explosion may occur during soldering. The tube is inflated by refrigerant pressure or additional pressure, which can cause injury.



7.4.1 RISK OF SUFFICATION

If a refrigerant leak occurs in a confined space, open all vents or turn on forced ventilation to ventilate the released gas and avoid the risk of suffocation.

7.5 SERVICE

If the heat pump does not work properly under reasonable use during the warranty period, please contact the seller.

The user has the responsibility to correctly manage and use the heat pump in accordance with this “Manual”. Malfunctions or problems caused by improper use are not covered by the warranty.

- The seller or the specified professional installer must perform maintenance and repair. Improper maintenance or repair may result in water leakage, electric shock, fire and/or damage to the heat pump.
- Contact the seller if the heat pump needs to be moved or reinstalled. Improper installation may cause water leakage, electric shock, fire and/or damage to the heat pump.

- If you need service, please contact the seller and provide the following information:
 - Model;
 - Serial number and date of manufacture;
 - Detailed description of the problem;
 - Your name, address and contact number.

If the warranty period has expired or the malfunction is caused by improper use, service costs may be charged.

7.6 DECOMMISSIONING

7.6.1 TEMPORARY DECOMMISSIONING

- Switch off the product.
- Disconnect the product from the power supply.

7.6.2 PERMANENTLY DECOMMISSIONING

- Switch off the product.
- Disconnect the product from the power supply.
- Drain the product. (→ Page 27)
- Dispose of or recycle the product and its components.

7.7 DISPOSAL

7.7.1 RECYCLING AND DISPOSAL OF HARDWARE

- The competent person who installed your product is responsible for the disposal of the packaging.

If the product is identified with this symbol:



- In this case, do not dispose of the product with the household waste.
- Instead, hand in the product to a collection centre for old electrical or electronic appliances.
- If the electrical products contains batteries that are marked with this symbol:



- These batteries may contain substances that are hazardous to human health and the environment.
- In this case, dispose of the batteries at a collection point for batteries.

7.7.2 DISPOSAL OF COOLANT



7.7.3 ENVIRONMENTAL DAMAGE

Coolant must not be allowed to escape into the atmosphere. R32 is a fluorinated greenhouse gas covered by the Kyoto Protocol, with a GWP of 1725 (GWP = Global Warming Potential).

- Before the product is disposed of, have the coolant which it contains completely drained into a suitable vessel so that it can then be recycled or disposed of in accordance with regulations.

The competent person who installed the heat pump must dispose of the coolant.

Personnel who are approved for energy recovery must have the relevant certification that corresponds to the valid regulations.

8 COPYRIGHT & DISCLAIMER

No part of this publication may be reproduced or transmitted in any form or by any means, electronic, mechanical, photocopying, recording or otherwise, without the prior written permission of the author.

While we have made reasonable efforts to make this document as accurate and useful as possible, we make no warranty, express or implied, as to the accuracy or completeness of the information contained herein. Spelling and typing errors reserved.

A wide-angle photograph of a snowy path leading through a field with wooden fences. The path is covered in a thick layer of snow, and the fences are made of light-colored wood. The background shows a clear blue sky and distant hills.

Adlår Castra UK
Juniper, Greenhills Estate,
Tilford Road, Tilford,
GU10 2DZ

T +44 (0) 1252 268 669
E info@adlar.com
W www.adlar.co.uk